



MEMBRANKOMPRESSOREN JDK-SERIE
DIAPHRAGM PUMPS JDK-SERIES

BIBUS – Netzwerk der Kompetenzen

Wir sind das Bindeglied zwischen den Herstellerwerken und unseren Kunden. Unsere langjährigen Handelsbeziehungen beruhen auf Kontinuität und Vertrauen. So erzielen wir für unsere Kunden beste Bedingungen.

Über 60 Jahre Erfahrung in den Fachgebieten Pneumatik, Mechatronik und Hydraulik haben BIBUS zu einem führenden Anbieter in der Europäischen Industrie gemacht.

Effiziente Logistik – unsere Kunden stellen höchste Anforderungen

Für unsere über 250.000 Standardartikel garantieren wir eine hohe Lieferbereitschaft. Moderne Lagersysteme mit Strichcodes und mobilen Datenerfassungsterminals sorgen für einen effizienten Warenfluss.

In 23 europäischen Ländern erbringen wir spezifische Service- und Reparaturleistungen und garantieren eine hohe Ersatzteilverfügbarkeit über den gesamten Produktlebenszyklus.

Qualität

Qualität mit den entsprechenden Qualifizierungen ist bei BIBUS selbstverständlich.



BIBUS – Network of competencies

We are the link between the manufacturing plants and our customers. Our many years of trading partnerships are based on continuity and trust. In this way we achieve the best possible conditions for our customers. Over 60 years of experience in the specialist areas of pneumatics, mechatronics and hydraulics have made BIBUS a leading provider in European industry.

Efficient logistics - our customers make the highest demands

We guarantee a high degree of availability for our more than 250,000 standard articles. Modern warehouse systems with barcodes and mobile data logging terminals ensure an efficient flow of goods.

We provide specific service and repairs in 23 European countries and guarantee a high degree of availability of spare parts throughout the product life cycle.

Quality

Quality and the relevant qualifications go without saying at BIBUS.



Anwendungsbeispiele



Examples of use



Funktionsprinzip

Aktiviert Elektromagnete versetzen einen Permanentmagneten in lineare Schwingung. Der Magnethalter bewegt sich nun mit der Frequenz der Stromversorgung – in der Regel 50 bzw. 60 Hz – zwischen den Elektromagneten hin und her und aktiviert jeweils eine Membrane, die das Ventilgehäusevolumen verändert. Durch die Entladung über die Ventile kann Überdruck sowie Unterdruck erzeugt werden.

Operating principle

The activated electromagnets put a permanent magnet into oscillation movements. The magnet holder moves now at the same frequency as that of the power supply – normally 50 Hz respectively 60 Hz – back and forth between the electromagnets and sets a diaphragm going on both sides, which then changes the valve box volume. By discharging via the valves, both pressure and vacuum can be realized.

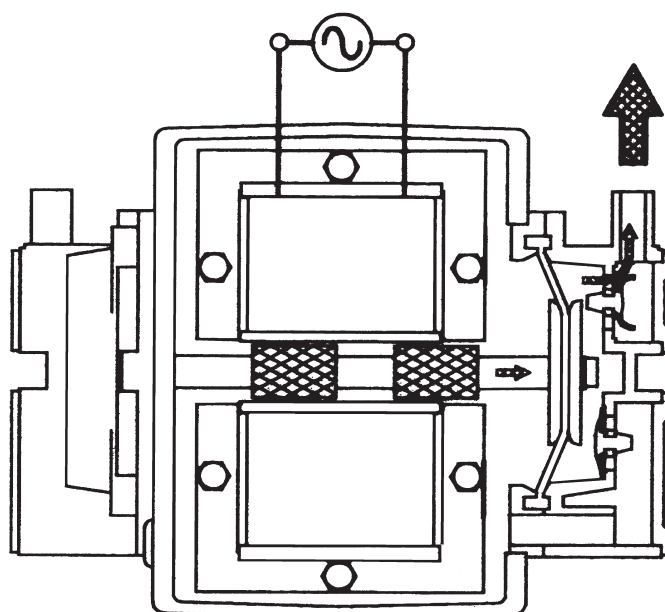

Ihr Nutzen

Lange Lebensdauer

Motor- und Pumpenteile sind in einem Gehäuse untergebracht. Die leichte und kompakte Bauform und der einfache Mechanismus gewährleisten einen langen und zuverlässigen Betrieb.

Hoher Wirkungsgrad

Mit Hilfe elektromagnetischer Oszillation, die praktisch keine mechanische Reibung aufweist, wird die Leistungsaufnahme minimiert und ein hoher Wirkungsgrad erreicht.

Niedriger Geräuschpegel

Ein schalldichtes Gehäuse und ein im Gehäuseboden integrierter Labyrinth-Dämpfer reduzieren das Betriebsgeräusch auf ein Minimum.

Geringe Vibration

Pumpen- und Außengehäuse sind durch einen Gummiabsorber voneinander getrennt, so dass nur eine geringe Vibration entsteht.

Ölfreier Betrieb

Der ölfreie Betrieb garantiert einen trockenen und unverfälschten Luftstrom.

Gleichförmiger Luftstrom

Speziell gestaltete Pumpenkammern und der im Gehäuseboden integrierte Labyrinth-Dämpfer gewährleisten einen Luftstrom, der nicht pulsiert.

Wetterbeständig

Alle Serien mit Gehäuse (SLL, EL, JDK) sind regenfest und können im Freien an leicht geschützten Orten aufgestellt werden.

Universelle Service-Kits

Für die jeweiligen Modellreihen stehen Service-Kits zur Verfügung. Für eine bessere und längere Haltbarkeit und Lagerung werden sie in einer Aluminiumfolie vakuumverpackt.

Your advantages

Long life expectancy

Motor and pump parts are combined in one single construction. The compact and light construction form and the simple mechanism guarantee a long and reliable period of operation.

High degree of efficiency

The principle of electromagnetic oscillation, which practically has no mechanical friction, minimises power consumption and provides a high degree of efficiency.

Low noise level

The soundproof casing and the muffler integrated in the tank base reduce operating noise.

Low vibration

Motor and pump parts are separated by a vibration-isolating rubber, so only low vibration consists.

Completely oil-free

The oil-free operation guarantees a dry and unadulterated air flow.

Pulsation-free air flow

Specially formed pump chambers and the muffler integrated in the tank base provide an air flow, which is practically pulsation-free.

Weatherproof

All series with a housing (SLL, EL, JDK) are rainproof and weatherproof. However, they should not be exposed to direct sunlight, rain or snow.

Universal service kits

For each model series service kits are available. They are vacuum-packed in aluminium foil for better and longer life/storage.

Achten Sie auf die richtige Pumpenleistung

Den technischen Daten verschiedener Kompressorhersteller liegen unterschiedliche Referenzdruckhöhen zugrunde. Wir empfehlen Ihnen daher, die Leistungsdaten der Kompressoren genau zu vergleichen.

Wir beraten Sie gerne, damit Sie das richtige Modell für Ihre Anwendung finden.

Choose the right pump capacity

The technical specifications from different diaphragm pump manufacturers are based on various reference pressure levels. We therefore recommend that you compare the performance data of the diaphragm pumps exactly.

We are happy to advise you so that you find the correct model for your application.



JDK Serie / JDK series

JDK-20 / JDK-30 / JDK-40 / JDK-50

Produktmerkmale

- Kompaktes Design
- Energieeffizient
- Kunststoffgehäuse
- Schlauchstück im Lieferumfang

Product characteristics

- Compact design
- Low energy consumption
- High quality plastic housing
- Connecting hose included in delivery

Abmessungen / Dimensions

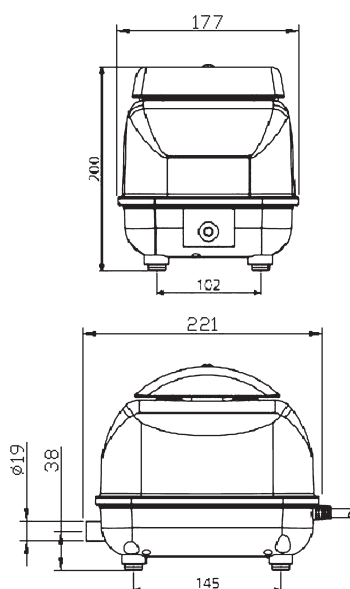

Technische Daten / Technical data

Modell / Model			JDK-20	JDK-30	JDK-40	JDK-50
Volumenstrom ¹⁾ / Air flow ¹⁾	l/min	0 mbar	50	58	65	72
		50 mbar	43	50	59	65
		100 mbar	34	41	50	59
		150 mbar	25	32	43	50
		200 mbar	15	23	34	40
Spannung ²⁾ / Voltage ²⁾	VAC		230			
Leistungsaufnahme / Power consumption	W	200 mbar	16	25	35	42
Geräuschpegel / Noise level	dB(A)		30	32	33	36
Abmessungen / Dimensions	mm	L x B x H L x W x H	221 x 177 x 200			
Schlauchanschluss / Connection	mm	Ø außen Ø outside	19			
Nettogewicht / Net weight	kg		4.5			

¹⁾ Die tatsächliche Leistung kann bis zu +/- 10% von den Angaben abweichen

²⁾ Werte bei 50 Hz

¹⁾ Product performance may vary +/- 10% from performance curves

²⁾ Values at 50 Hz

Ersatzteile / Zubehör Spare Parts / Accessories

Ersatzteile / Spares	Bestell-Nr. / Code
Reparatur-Kit / Service Kit	K-JDK-20/50-D
Membran-Set / Diaphragm Sets	D-SLL
Filter / Filter	FILTER-JDK-20/50
Magnet / Magnet	K-SLL-M
Zubehör / Accessories	
Manometer / Pressure Gauge	BP1
Drucksicherheitsventil / Pressure Relief Valve	SE11

Leistungsdaten / Performance data

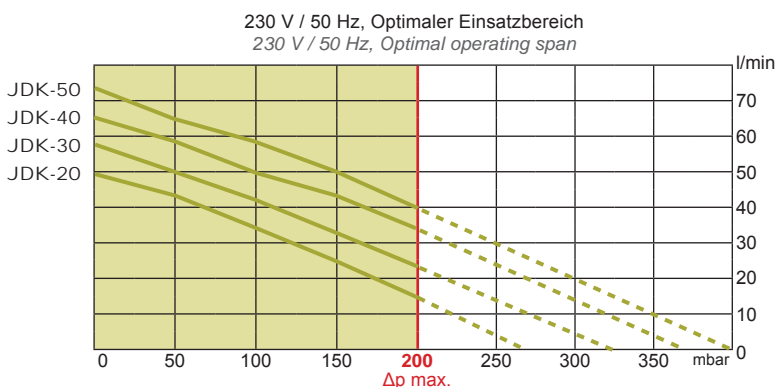



JDK Serie / JDK series

JDK-60 / JDK-80 / JDK-100 / JDK-120

Produktmerkmale

- Kompaktes Design
- Energieeffizient
- Schutzschalter inklusive
- Optional auch mit Signalkabel
- Schlauchstück im Lieferumfang
- Metallgehäuse

Product characteristics

- Compact design
- Low energy consumption
- Protective switch inclusive
- Optional with signal cable
- Connecting hose incl. in delivery
- metal housing

Abmessungen / Dimensions

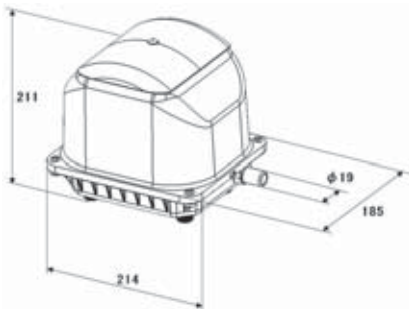

Technische Daten / Technical data

Modell / Model		JDK-60	JDK-80	JDK-100	JDK-120	
Volumenstrom ¹⁾ / Air flow ¹⁾	l/min	0 mbar	130	145	150	190
		50 mbar	125	130	145	180
		100 mbar	105	115	130	160
		150 mbar	85	90	110	140
		200 mbar	60	75	95	120
Spannung ²⁾ / Voltage ²⁾	VAC	230				
Leistungsaufnahme / Power consumption	W	200 mbar	40	50	75	95
Geräuschpegel / Noise level	dB(A)		≤ 41	≤ 43	≤ 42	≤ 45
Abmessungen / Dimensions	mm	L x B x H L x W x H	214 x 185 x 211			
Schlauchanschluss / Connection	mm	Ø außen Ø outside	19			
Nettogewicht / Net weight	kg		6.5			

¹⁾ Die tatsächliche Leistung kann bis zu +/- 10% von den Angaben abweichen

²⁾ Werte bei 50 Hz

¹⁾ Product performance may vary +/- 10% from performance curves

²⁾ Values at 50 Hz

Ersatzteile / Zubehör Spare Parts / Accessories

Ersatzteile / Spares	Bestell-Nr. / Code
Reparatur-Kit / Service Kit	K-JDK-60/80-D K-JDK-100/120-D
Membran-Set / Diaphragm Sets	D-JDK-60/120
Filter / Filter	FILTER-JDK-60/120
Magnet / Magnet	K-JDK-60/120-M
Zubehör / Accessories	
Manometer / Pressure Gauge	BP1
Drucksicherheitsventil / Pressure Relief Valve	SE11

Leistungsdaten / Performance data

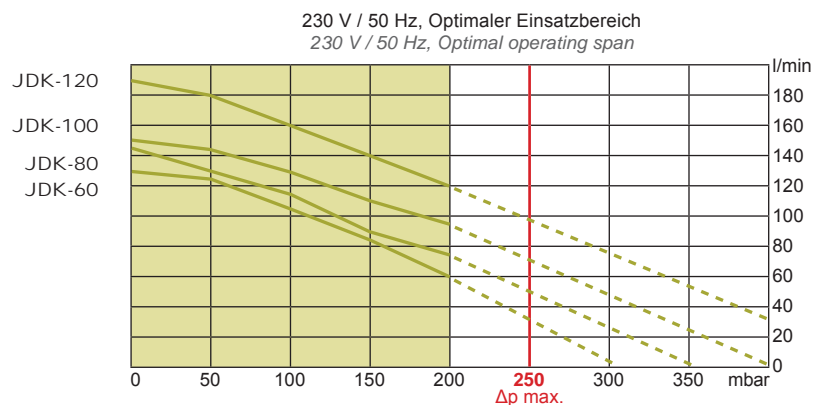



TKO Serie / *TKO series*

TKO-150 / TKO-200 / TKO-250

Produktmerkmale

- Kompaktes Design
- Energieeffizient
- Metallgehäuse

Product characteristics

- Compact design
- Low energy consumption
- High quality metal housing

Abmessungen / *Dimensions*

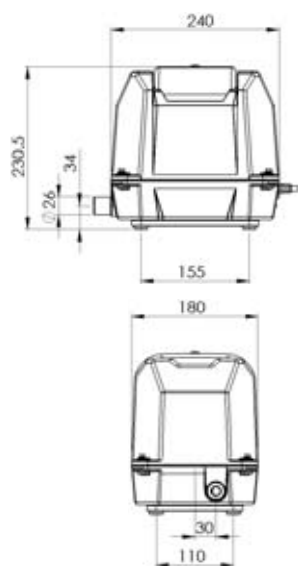

Technische Daten / *Technical data*

Modell / <i>Model</i>			TKO-150	TKO-200	TKO-250
Volumenstrom ¹⁾ / <i>Air flow¹⁾</i>	l/min	0 mbar	270	290	340
		50 mbar	240	270	325
		100 mbar	210	245	300
		150 mbar	180	220	270
		200 mbar	150	200	250
Spannung ²⁾ / <i>Voltage²⁾</i>	VAC	230			
Leistungsaufnahme / <i>Power consumption</i>	W	200 mbar	115	180	225
Geräuschpegel / <i>Noise level</i>	dB(A)		44	46	52
Abmessungen / <i>Dimensions</i>	mm	L x B x H L x W x H	240 x 180 x 230.5		
Schlauchanschluss / <i>Connection</i>	mm	Ø außen Ø outside	26		
Nettogewicht / <i>Net weight</i>	kg		10		

¹⁾ Die tatsächliche Leistung kann bis zu +/- 10% von den Angaben abweichen

²⁾ Werte bei 50 Hz

¹⁾ Product performance may vary +/- 10% from performance curves

²⁾ Values at 50 Hz

Ersatzteile / Zubehör *Spare Parts / Accessories*

Ersatzteile / <i>Spares</i>	Bestell-Nr. / <i>Code</i>
Reparatur-Kit / <i>Service Kit</i>	K-JDK-150/500-D
Membran-Set / <i>Diaphragm Sets</i>	D-JDK-150/500
Filter / <i>Filter</i>	FILTER-JDK-150/500
Magnet / <i>Magnet</i>	K-JDK-150/200-300/400-M
	K-JDK-250/500-M
Zubehör / <i>Accessories</i>	
Manometer / <i>Pressure Gauge</i>	BP1

Leistungsdaten / *Performance data*

230 V / 50 Hz, Optimaler Einsatzbereich
230 V / 50 Hz, Optimal operating span

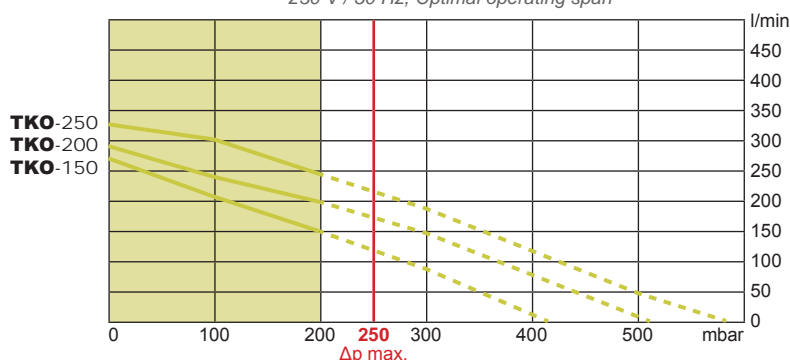



TKO Serie / *TKO series* TKO-300 / TKO-400 / TKO-500

Produktmerkmale

- Kompaktes Design
- Energieeffizient
- Metallgehäuse

Product characteristics

- Compact design
- Low energy consumption
- High quality metal housing

Abmessungen / *Dimensions*

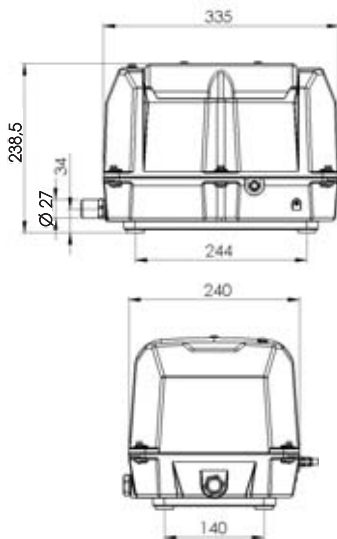

Technische Daten / *Technical data*

Modell / Model			TKO-300	TKO-400	TKO-500
Volumenstrom ¹⁾ / Air flow ¹⁾	l/min	0 mbar	525	600	700
		50 mbar	480	560	655
		100 mbar	430	510	600
		150 mbar	375	460	545
		200 mbar	300	400	500
Spannung ²⁾ / Voltage ²⁾	VAC		230		
Leistungsaufnahme / Power consumption	W	200 mbar	230	360	450
Geräuschpegel / Noise level	dB(A)		52	54	58
Abmessungen / Dimensions	mm	L x B x H L x W x H	335 x 240 x 238.5		
Schlauchanschluss / Connection	mm	Ø außen Ø outside	27		
Nettogewicht / Net weight	kg		18		

¹⁾ Die tatsächliche Leistung kann bis zu +/- 10% von den Angaben abweichen

²⁾ Werte bei 50 Hz

¹⁾ Product performance may vary +/- 10% from performance curves

²⁾ Values at 50 Hz

Ersatzteile / Zubehör *Spare Parts / Accessories*

Ersatzteile / Spares	Bestell-Nr. / Code
Reparatur-Kit / Service Kit	K-JDK-150/500-D
Membran-Set / Diaphragm Sets	D-JDK-150/500
Filter / Filter	FILTER-JDK-150/500
Magnet / Magnet	K-JDK-150/200-300/400-M K-JDK-250/500-M
Zubehör / Accessories	
Manometer / Pressure Gauge	BP1

Leistungsdaten / *Performance data*

230 V / 50 Hz, Optimaler Einsatzbereich
230 V / 50 Hz, Optimal operating span

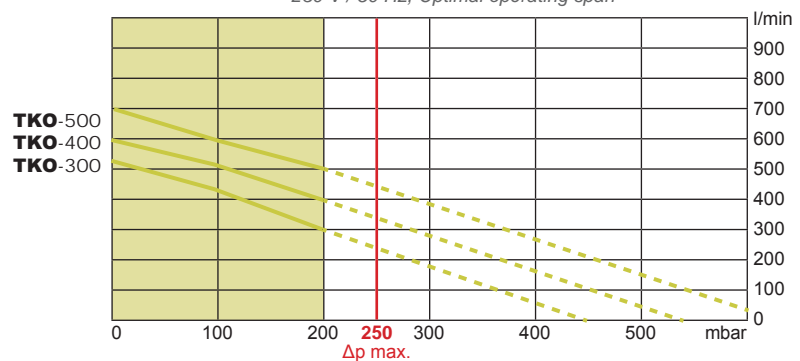

Ersatz- und Zubehörteile / *Spare Parts and Accessories*

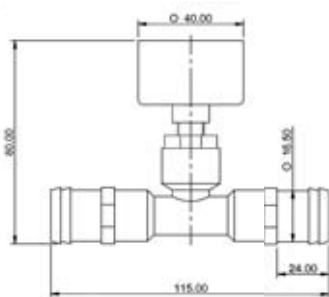

Manometer /
Back Pressure Gauge
(BP1)

Druckbereich <i>Pressure Range</i>	0 - 0.6 bar
Maße (L x B x H) <i>Dimensions (L x W x H)</i>	115 x 40 x 80 mm
Anschluss / <i>Connection</i>	19 Ø mm
Gewicht / <i>Net weight</i>	0.25 kg

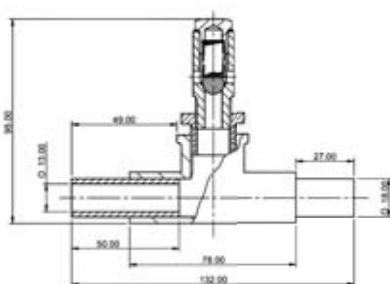

Druckbegrenzungsventil /
Pressure Relief Valve
JDK-50 / 120 (SE11)

Druckbereich <i>Pressure Range</i>	200, 250, 300 mbar
Maße (L x B x H) <i>Dimensions (L x W x H)</i>	132 x 30 x 95 mm
Anschluss / <i>Connection</i>	19 Ø mm
Gewicht / <i>Net weight</i>	0.5 kg



Ersatz- und Zubehörteile / Spare Kits and Accessories

Verdichtermodell / Blower Model	JDK-20	JDK-30	JDK-40	JDK-50
Ersatzteilbezeichnung / Name of Spare Part				
Filter / Filter	Filter-JDK-20/-50			
Membranset / Diaphragm Sets	D-SLL			
Reparaturkit / Service Kit	K-JDK-20/50-D			
Magnet / Magnet	K-SLL-M			
Zubehör / Accessories				
Manometer / Back Pressure Gauge	BP1			
Drucksicherheitsventil / Pressure Relief Valve	SE11			



Verdichtermodell / Blower Model	JDK-60	JDK-80	JDK-100	JDK-120
Ersatzteilbezeichnung / Name of Spare Part				
Filter / Filter	Filter-JDK-60/-120			
Membranset / Diaphragm Sets	D-JDK-60/120			
Reparaturkit / Service Kit	K-JDK-60/80-D		K-JDK-100/120-D	
Magnet / Magnet	K-JDK-60/120-M			
Zubehör / Accessories				
Manometer / Back Pressure Gauge	BP1			
Drucksicherheitsventil / Pressure Relief Valve	SE11			



Verdichtermodell / Blower Model	TKO-150	TKO-200	TKO-250	TKO-300	TKO-400	TKO-500
Ersatzteilbezeichnung / Name of Spare Part						
Filter / Filter	Filter-TKO-150/-500					
Membranset / Diaphragm Sets	D-TKO-150/500					
Reparaturkit / Service Kit	K-TKO-150/500-D					
Magnet / Magnet	K-TKO-150/200-300/400-M		K-TKO-250/500-M	K-TKO-150/200-300/400-M		K-TKO-250/500-M
Zubehör						
Manometer / Back Pressure Gauge	BP1					

Technical References

The following explanations are to help interpret technical data, performance diagrams and dimensioned drawings correctly.

Air flow

Air flow in reference to the corresponding operating pressure

Optimal operating span

Pressure range at which the diaphragm pump can operate continuously.

Special care is necessary, when the pump is operating in the range of maximum working pressure. Please enquire our technical support for special cases.

Power consumption

Input wattage that appears at the stated pressure. The power consumption is at open flow. An exact curve about power consumption is available on request.

Operation mode

Our pumps are designed and produced for permanent operation if the use complies with the operating conditions.

Power supply

All data given refer to an electricity supply of 230VAC / 50Hz, with variations up to +/- 10% are acceptable. All models also run with a frequency of 60 Hz, however with varying performance. Models for other tensions are available on request.

Overload protection

The SLL, SV, EL and JDK series are supplied with an integrated thermal overload protection. The contact breaks when the temperature of the windings reaches hazard value of the probe at 130° C until the coil has cooled down below 120° C.

Protection class

Phoe-niX series: IPX4, SLL series: IP45, EL and JDK-series: IP44

Ambient temperature

The maximum ambient and suction temperature ranges from -10 to +40° C.

Insulation class

All models have the insulation class „E“, which corresponds to a temperature limit of 120° C.

Life expectancy

The working life depends on the operating conditions (duty cycle, operation pressure or vacuum, etc.) and the work environment (ambient temperature, air quality, ventilation, maintenance, etc.).

Protective switch (auto stopper)

Our diaphragm pumps are equipped with an auto-stop function and an LED lamp that signals a possible diaphragm break or magnet off-set (JDK-series only!) on the outer enclosure. In addition, the auto-stop function interrupts the power supply to the motor should e.g. a diaphragm ever be broken. This prevents further consequential damage, which could be severe, to the diaphragm pumps and the connected systems.

Fault alarm lamp

To indicate any fault mentioned above optically, every pump of the EL-S- and JDK-S-series is provided with a fault alarm lamp.

On customer request there is also the possibility to register faults alternatively by an integrated signal cable.

Test conditions

The information presented in this catalogue is based on technical data and test results of nominal units. The measured values refer to a power supply of 230 VAC / 50 Hz and an ambient temperature of 15 to 25° C. The volume flows were measured with air.

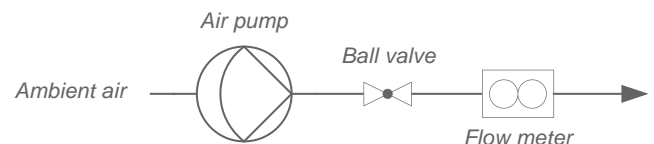

Installation and operation

Installation

The pump must always be installed above the water level. If the pump is set below, the back-flowing water can cause an electrical short circuit.

The pump should be installed at least 10 cm higher than the foundation on a stable platform. If installed on an unstable base, noise from vibrations can result. The pump must be located on a levelled platform to prevent biased strain on the diaphragm that could lead to reduced component life of the blower.

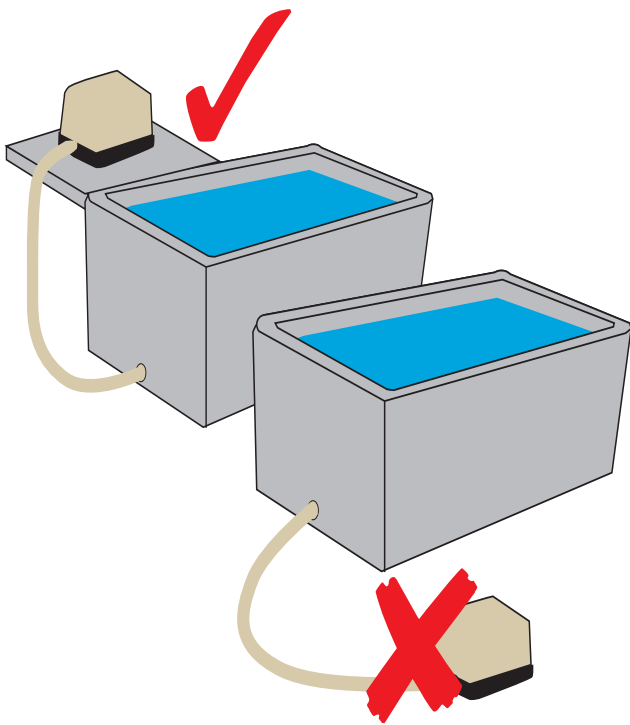

Ambience

Ensure that the unit has good ventilation, especially when subjected to severe operating conditions. If installed in a control cabinet, sufficient ventilation by louvered vents is essential. A cool ambience will ensure longer diaphragm and valve life. The diaphragm blowers are weatherproof. However, they should not be exposed to direct sunlight, rain or snow.

Air quality

The diaphragm pumps are specially developed for transporting air. They should not be operated in a dusty environment. The blocked filter may cause overheating. The atmosphere humidity should not be higher than 90%. Inflammable or aggressive gases and vapours should not enter the pump as the flow path leads to current-carrying parts.

Piping

Select tube size, lengths and accessories to keep pressure loss as small as possible.

Apply:

- straight piping and as short as possible
- tubing, which diameter is bigger than the port of the unit (inside diameter min. 19 mm, respective 27 mm for twin systems)
- large radius bends and no elbows
- valves of bigger diameter than the blower's connector port
- smooth-running valves that provide the lowest pressure drop
- low air loss diffusers for aeration

Maintenance

Clean the filter regularly and replace broken diaphragms immediately. Complete repair kits are available.

Storage

The pumps may not be stored at less than -10°C . The permanent magnet would be weakened in such a case, and the performance would not be as expected. The pump may not be stored in direct sunlight or at high temperatures to maintain the rubber parts flexible.

ENTWICKLUNG / *ENGINEERING*

LOGISTIK / *LOGISTICS*

SERVICE / *SERVICES*



BIBUS (THAILAND) CO.,LTD.

181/68 Soi Nuanchan 32 Nuanchan Buengkhum District
Bangkok 10230 Thailand

Phone +66 90 894 9867

Fax +66 2 054 6576

Email: info@bibus.co.th

www.bibus.co.th