

GAS SPRINGS

GAS TRACTION SPRINGS

STAINLESS STEEL GAS SPRINGS

DAMPERS

ACCESSORIES

GENERAL INFORMATION

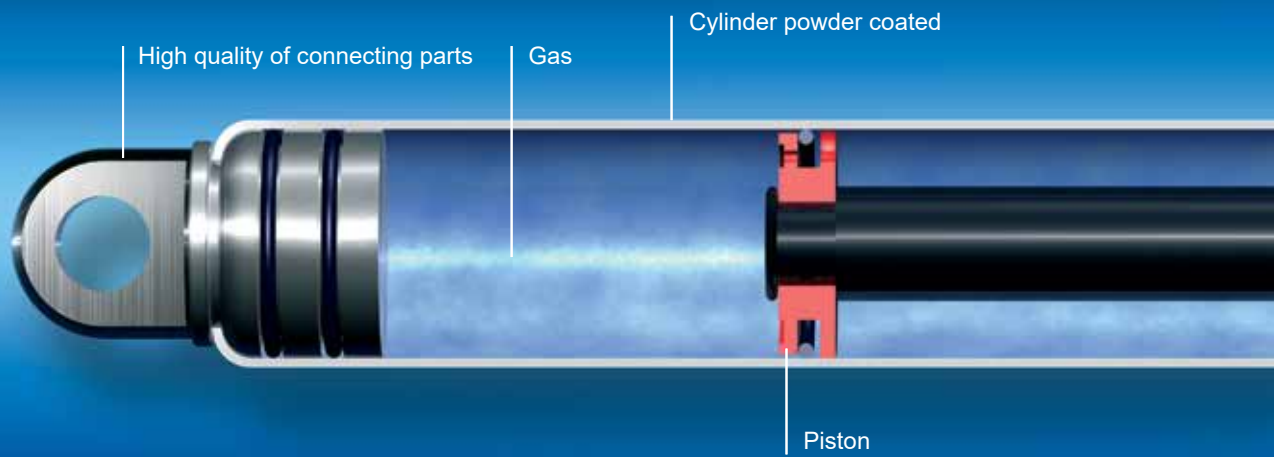

High quality



The connecting parts are available in many variations



Cylinder is made out of steel and powder-coated (available in black, white and silver)

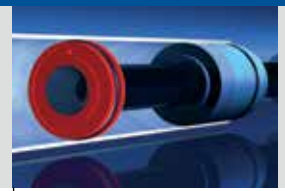

Piston for speed control

You wish to **push, pull, lift, lower or position** a load, a cover, a hood or other manual system without using an external energy source and especially by minimizing the effort of the operator?

The gas springs we offer from Bansbach can be supplied to specific pressures (Extension forces) to suit your application..

FORCES DIAGRAM

The theoretical thrust force is determined by the inflation pressure multiplied by the piston rod cross-section. By varying both factors, it is possible to deliver gas springs in a range from 10 N to 5000 N. The nominal thrust force is always that measured at point F1 at 20°C +/- 2°C and the piston rod at the bottom. For a compression gas spring, the force measurement points are as follow:

- F1 = Push force, piston rod extended
- F2 = Push force, piston rod retracted
- F3 = Force to be applied, piston rod extended
- F4 = Force to be applied, piston rod retracted
- FR = Frictions

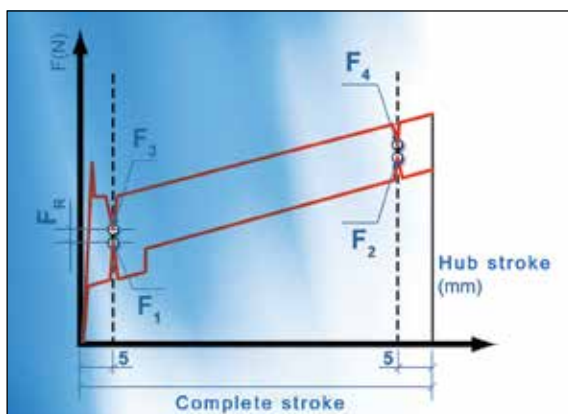

These forces are measured dynamically at 5 mm on either side of the total stroke (release stroke to be added for lockable models). A static measurement doesn't produce compliant results.

Bansbach gas springs are known for their **high efficiency** (friction very low due to very high quality materials and machining) and **regular thrust**.

By modulating the size of the piston rod orifices and the quantity of oil, it is possible to control the input / output speed, end of stroke damping and progressiveness.

The values in the diagram above can be influenced by the gas volume and oil quantity (thrust ratio between F2 and F1).

Gas spring composition

- **Piston rod:** Steel (standard models) or aluminium (on request) (*) Ceramic surface treatment of steel (CeramPro®), with a resistance of 200 hours in salt fog.
- **Tube:** Steel (standard models) or aluminium (on request) (*) Treatment by powder-coated, whose lifetime, shock and scratch resistance are superior to liquid paint (black epoxy paint as standard, other colors on request).
- **Connecting parts, hinge:** Steel or Lead-free aluminium (*)
- **Sealing ring, oil, grease chamber:** Do not contain any substances listed as harmful or hazardous.
- **Nitrogen:** Inert gas that doesn't ignite. Doesn't represent any health hazard.

(*) BIBUS also offers a range of gas springs with 316L and 304 stainless steel cylinders, piston rods and connecting parts in size 10/22 only.

CeramPro®

CéramPro® piston rod



High quality of connecting parts



A high-quality and unique guiding piece with integrated grease chamber

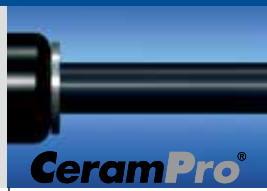

Ceram Pro® piston rod, extremely rust and corrosion resistant



Connecting part available in many variations

Further Informations

- **Force tolerance:** -20N to +40N or 5 to 7%. Depending on gas spring size and force, tolerances may vary.
- **Effect of temperature:** about 3.3% every 10°C. indicated force at 20°C
- **Operating temperatures :** -30°C to +80°C (option of -45°C to +200°C)
- **Integrated valve:** located at the rear of the cylinder, it reduces the force on your site with the corresponding U exhaust screw (to be ordered separately) - re-charge in the workshop or with the filling case
- **Mounting:** in any position but we advise piston rod down in order to benefit from end-position damping. Provide a fixed stop at the end of the stroke if external forces are high. Avoid radial stresses - in case of strong vibrations or safety application, the connecting parts must be bonded to avoid any risk of loosening.

ITEM DEFINITION

Gas spring

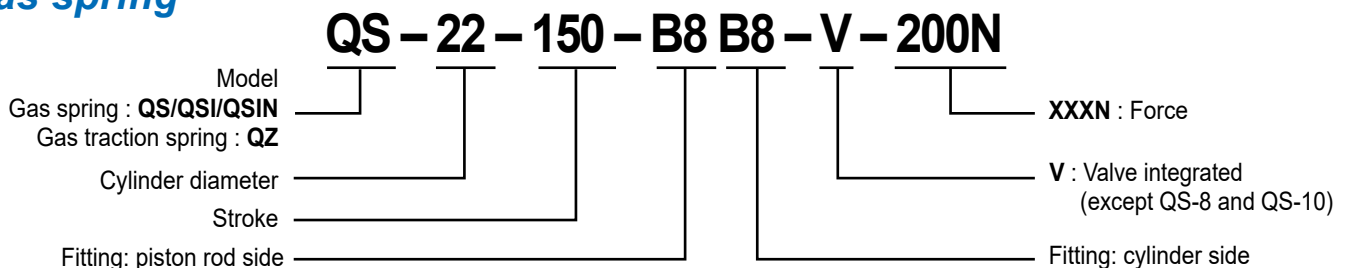

Damper

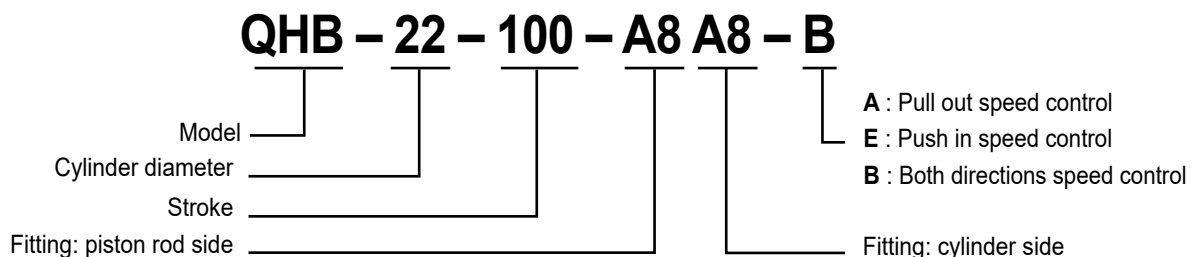

All designs, dimensions and specifications are subject to change without notification. (May 2020)

DO YOU HAVE A PROJECT ? WE CAN HELP YOU ...

Can I use a gas spring in my application?

If so, which one is best suited for my application and how should it be designed?

It is very easy – we would be pleased to help you. Just make a simple sketch (similar to the one on the left) of a application and be sure to note: weight, center of gravity, dimensions, field of traverse in degrees and the requested hand-force (holding- force).

Please note that all dimensions should be measured from the pivot (hinge).

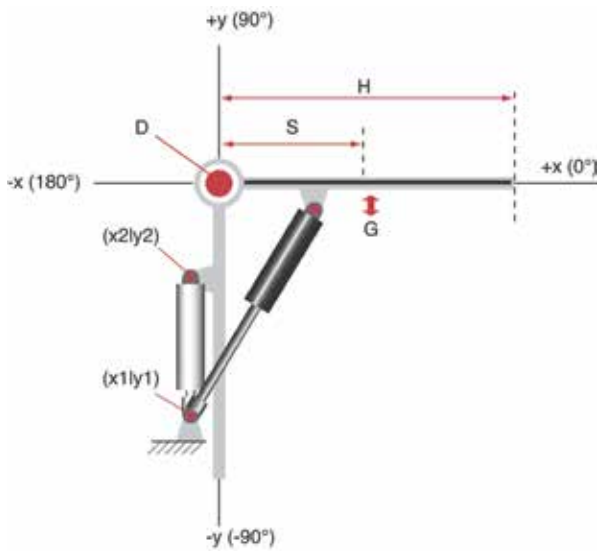

Data to communicate to us:

- Hood length (L*): _____ mm
 - Center of gravity distance (S*): _____ mm
 - Mass of the element to be balanced (G): _____ kg
 - Starting angle // horizontally : _____ °
 - Opening angle: _____ °
 - Number of gas springs in parallel _____
 - Number of motion: _____ / day
 - Ambient temperature: _____ °C
 - Type of connecting parts - piston rod / cylinder side: ____ / ____
- (*) : in relation to the rotational center

OUR TOOLS

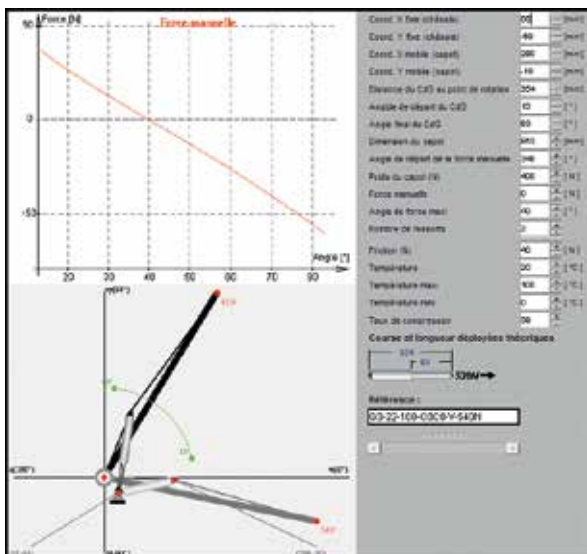

We have has a software to simulate your application and produce the effort curve in relation to the motion. Thus, our commercial offers are systematically accompanied by a full report detailing:

- The model of the selected gas spring
- The force F1
- The installation of the gas spring on the fixed part and on the moving part
- The effort curve, respecting the maximum permitted by the occupational medicine

These elements will allow you a simplified installation of the gas spring, thus an efficiency gain.

This determination service is provided free of charge.

***Move
without effort***



<i>Gas Spring</i>	6
<i>Stainless Steel Gas Spring</i>	13
<i>Gas Traction Spring</i>	16
<i>Damper</i>	18

QS-8 : F_1 from 10 to 100N ($F_{2 \max} = 120N$) **QS-10 : F_1 from 10 to 100N ($F_{2 \max} = 120N$)**

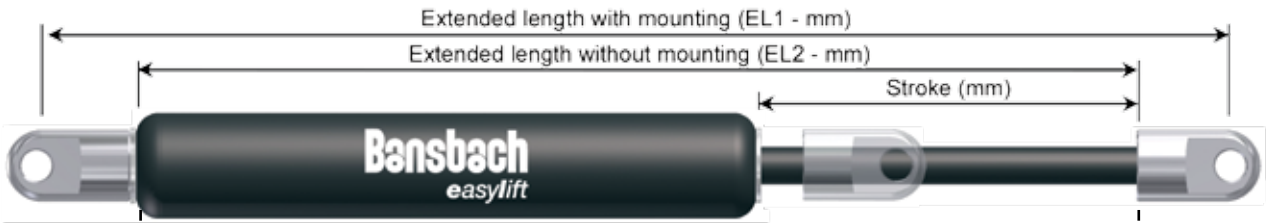

Item	Stroke (+/- 2mm)	EL2 (+/- 2mm)
QS-8-20	20	72
QS-8-30	30	92
QS-8-40	40	112
QS-8-50	50	132
QS-8-60	60	152
QS-8-80	80	192

(*) In stock

Diameter piston rod/cylinder: \varnothing 3mm / \varnothing 8mm

Valve: without

Fitting: thread piston rod/cylinder: M3*4 / M3*4

Progressivity: approx. 28%

Speed & damping: normal speed – normal damping over 5 mm

Materials: ceramic treatment on the piston rod (Corrosion resistance 216 h according to DIN 50021 SS) - brass cylinder

Item	Stroke (+/- 2mm)	EL2 (+/- 2mm)
QS-10-20	20	72
QS-10-30	30	92
QS-10-40	40	112
QS-10-50	50	132
QS-10-60	60	152
QS-10-80	80	192

(*) In stock

Diameter piston rod/cylinder: \varnothing 3mm / \varnothing 10mm

Valve: without

Fitting: thread piston rod/cylinder: M3*4 / M3*4

Progressivity: approx. 16%

Speed & damping: normal speed – normal damping over 10 mm

Materials: ceramic treatment on the piston rod (Corrosion resistance 216 h according to DIN 50021 SS) - Black epoxy paint on the cylinder

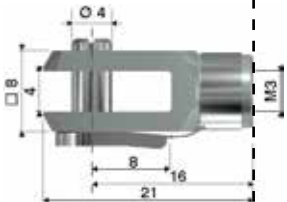
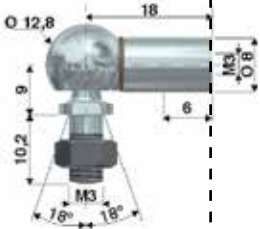
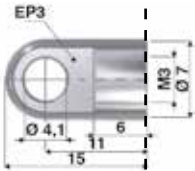

B3

A3

Load max. 370N

C3

Load max. 370N

D3

Load max. 370N

G3

Load max. 370N

QS-12 : F₁ from 10 to 180N (F₂ max = 225N)

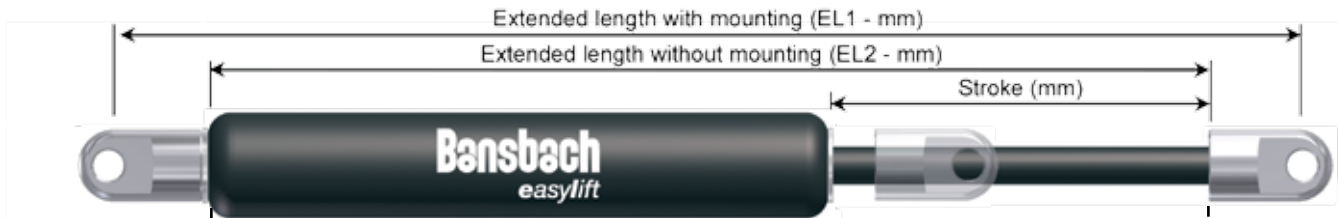

Item	Stroke (+/- 2mm)	EL2 (+/- 2mm)
QS-12-20	20	72
QS-12-30 *	30	92
QS-12-40	40	112
QS-12-50	50	132
QS-12-60	60	152
QS-12-80 *	80	192
QS-12-100 *	100	232
QS-12-120	120	272
QS-12-150	150	332

(*) In stock

Diameter piston rod/cylinder: Ø 4mm / Ø 12mm
Valve: integrated
Fitting: thread piston rod/cylinder: M4*4 / M4*4
Progressivity: approx. 21%
Speed & damping: normal speed – normal damping over 10 mm
Materials: ceramic treatment on the piston rod (Corrosion resistance 216 h according to DIN 50021 SS) - Black epoxy paint on the cylinder

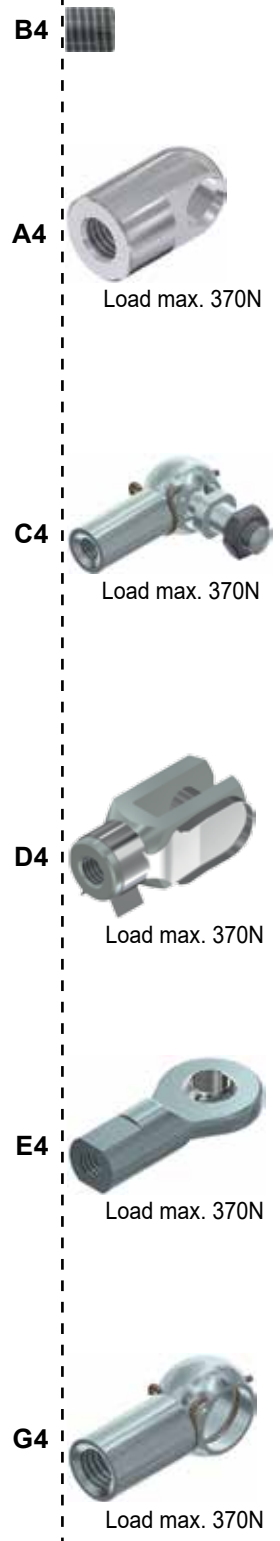
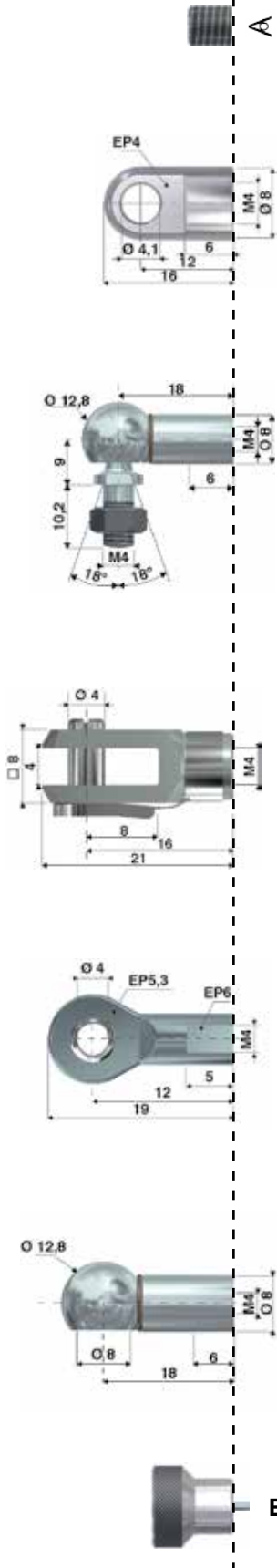

QS-15 : F₁ from 20 to 400N (F₂ max = 500N)

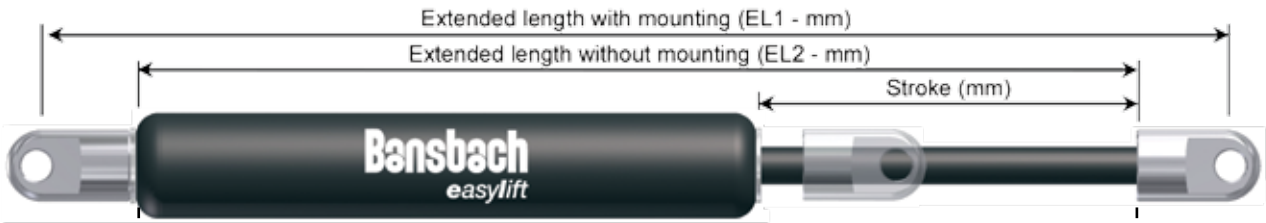

Item	Stroke (+/- 2mm)	EL2 (+/- 2mm)
QS-15-20 *	20	67
QS-15-40 *	40	107
QS-15-50 *	50	127
QS-15-60 *	60	147
QS-15-80 *	80	187
QS-15-100 *	100	227
QS-15-120 *	120	267
QS-15-150 *	150	327
QS-15-200 *	200	427

(*) In stock

Diameter piston rod/cylinder: Ø 6mm / Ø 15mm

Valve: integrated

Fitting: thread piston rod/cylinder: M5*5 / M5*5

Progressivity: approx. 34%

Speed & damping: normal speed – normal damping over 10 mm

Materials: ceramic treatment on the piston rod (Corrosion resistance 216 h according to DIN 50021 SS) - Black epoxy paint on the cylinder

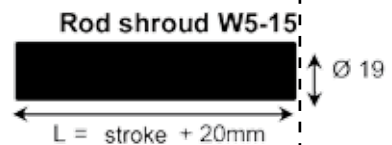
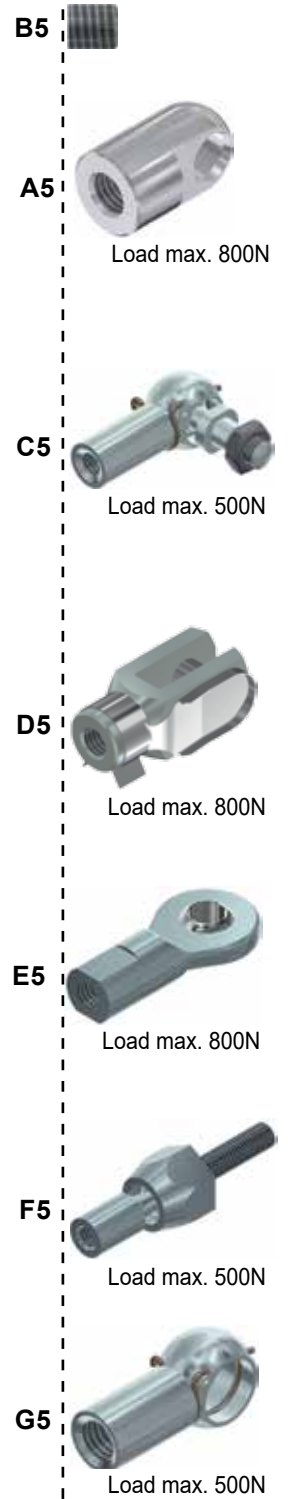
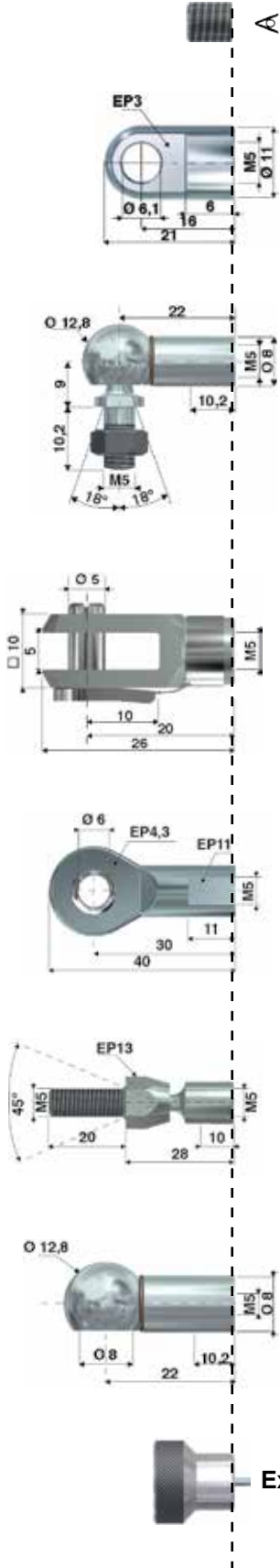



Item	Stroke (+/- 2mm)	EL2 (+/- 2mm)
QS-19-50 *	50	164
QS-19-100 *	100	264
QS-19-150 *	150	364
QS-19-200 *	200	464
QS-19-250 *	250	564
QS-19-300 *	300	664

(*) In stock

Diameter piston rod/cylinder: Ø 8mm / Ø 19mm
Valve: integrated
Fitting: thread piston rod/cylinder: M8*9 / M8*8
Progressivity: approx. 40%
Speed & damping: low speed – high damping between 20mm to 60mm according to the stroke
Materials: ceramic treatment on the piston rod (Corrosion resistance 216 h according to DIN 50021 SS) - Black epoxy paint on the cylinder

Item	Stroke (+/- 2mm)	EL2 (+/- 2mm)
QS-22-50 *	50	164
QS-22-100 *	100	264
QS-22-150 *	150	364
QS-22-200 *	200	464
QS-22-250 *	250	564
QS-22-300 *	300	664
QS-22-350 *	350	764
QS-22-400 *	400	864
QS-22-450 *	450	964
QS-22-500 *	500	1064
QS-22-550 *	550	1164
QS-22-600 *	600	1264
QS-22-650 *	650	1364
QS-22-700	700	1464

(*) In stock

Diameter piston rod/cylinder: Ø 10mm / Ø 22mm
Valve: integrated
Fitting: thread piston rod/cylinder: M8*9 / M8*8
Progressivity: approx. 45%
Speed & damping: low speed – high damping between 20mm to 70mm according to the stroke
Materials: ceramic treatment on the piston rod (Corrosion resistance 216 h according to DIN 50021 SS) - Black epoxy paint on the cylinder

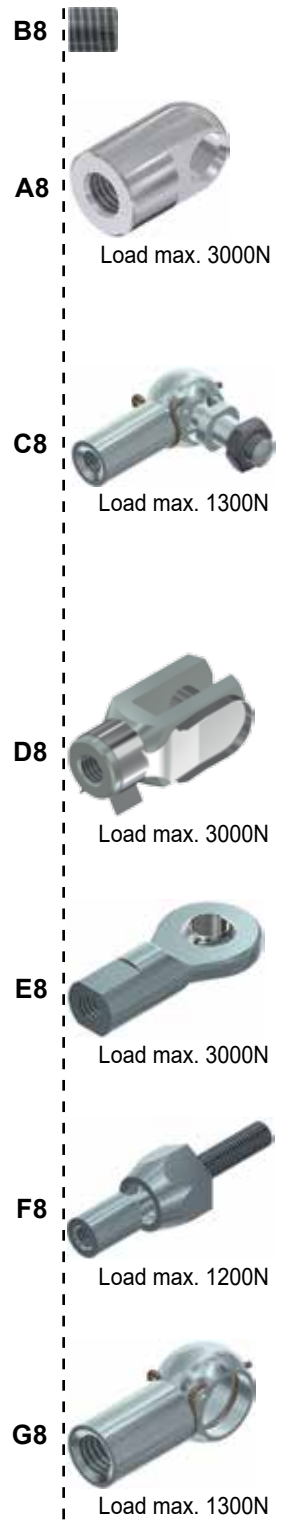
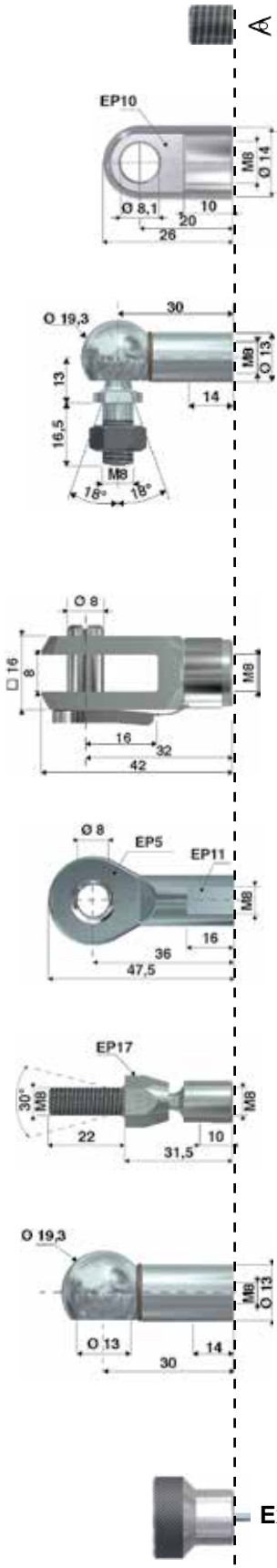

QS-28 : F₁ from 150 de 2500N (F₂ max = 3800N)

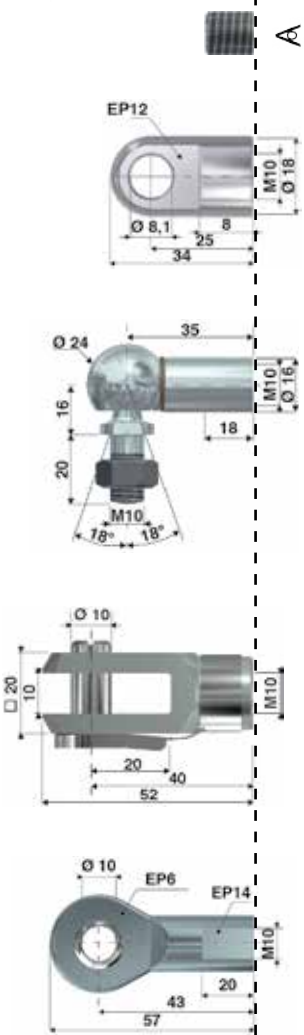
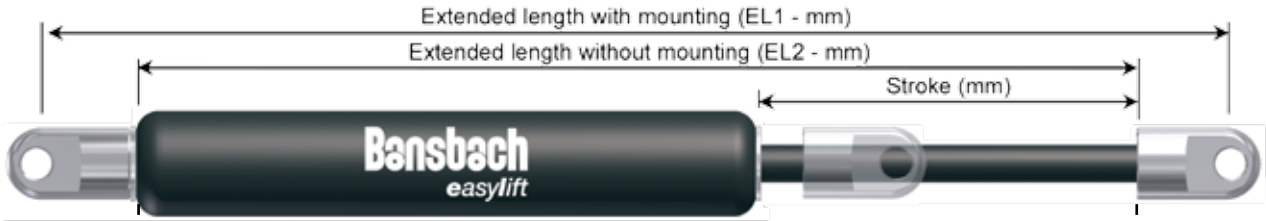

Item	Stroke (+/- 2mm)	EL2 (+/- 2mm)
QS-28-100 *	100	262
QS-28-150 *	150	362
QS-28-200 *	200	462
QS-28-250 *	250	562
QS-28-300 *	300	662
QS-28-350 *	350	762
QS-28-400 *	400	862
QS-28-450	450	962
QS-28-500 *	500	1062
QS-28-550	550	1162
QS-28-600 *	600	1262
QS-28-650 *	650	1362
QS-28-700	700	1462
QS-28-750	750	1562

(*) In stock

Diameter piston rod/cylinder: Ø 14mm / Ø 28mm
Valve: integrated
Fitting: thread piston rod/cylinder: M10*9 / M10*13
Progressivity: approx. 80% for stroke from 100 to 350mm
 65% for stroke from 400 to 750mm
Speed & damping: low speed – high damping between 30mm to 70mm according to the stroke
Materials: ceramic treatment on the piston rod
 (Corrosion resistance 216 h according to DIN 50021 SS) -
 Black epoxy paint on the cylinder

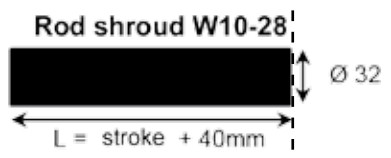
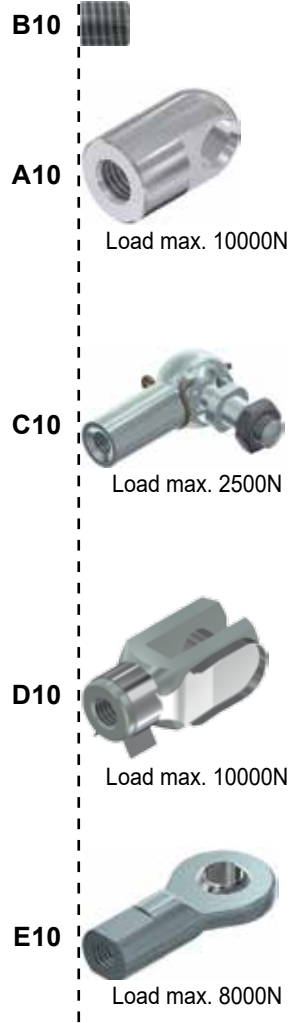

QS-40 : F₁ from 500 to 5000N (F_{2 max} = 7250N)

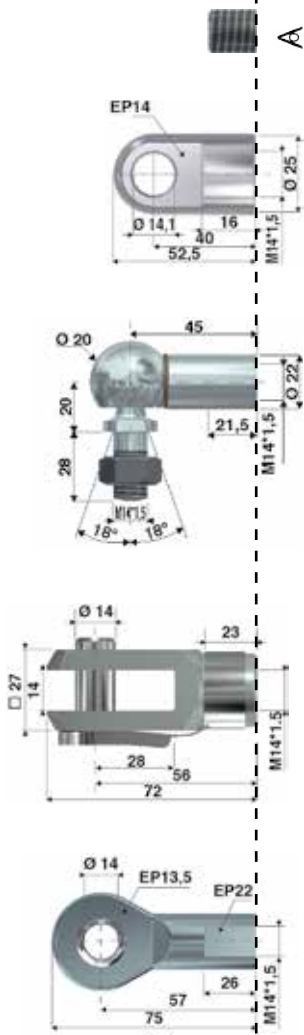
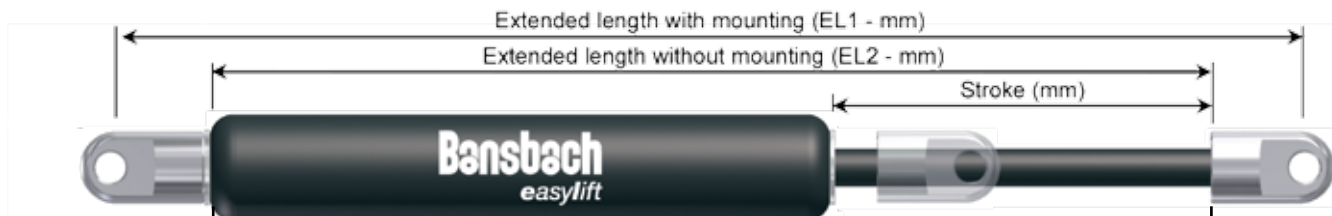

Item	Stroke (+/- 2mm)	EL2 (+/- 2mm)
QS-40-100	100	317
QS-40-150 *	150	417
QS-40-200 *	200	517
QS-40-300 *	300	717
QS-40-400 *	400	917
QS-40-500 *	500	1117
QS-40-600 *	600	1317
QS-40-800	800	1717
QS-40-1000	1000	2117

(*) In stock

Diameter piston rod/cylinder: Ø 20mm / Ø 40mm
Valve: integrated
Fitting: thread piston rod/cylinder: MF14*15 / MF14*15
Progressivity: approx. 48%
Speed & damping: low speed – high damping between 30mm to 70mm according to the stroke
Materials: ceramic treatment on the piston rod (Corrosion resistance 216 h according to DIN 50021 SS) - Black epoxy paint on the cylinder

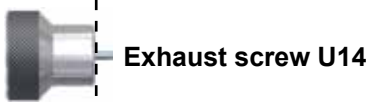
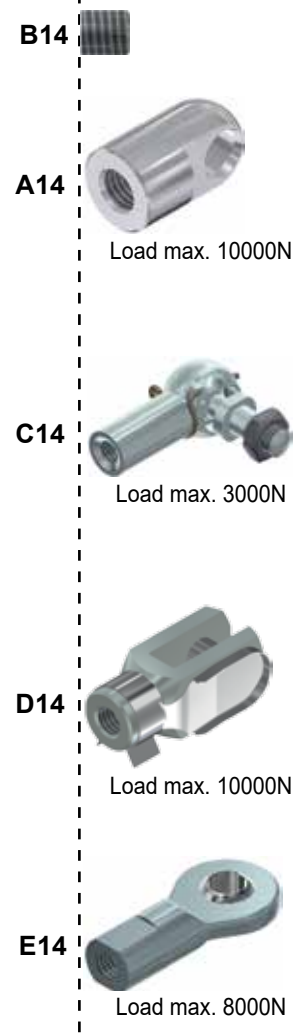

QS-70 : F₁ from 2000 to 13000N (F_{2 max} = 16250N)

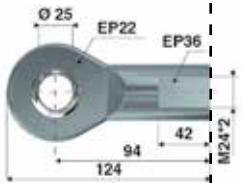
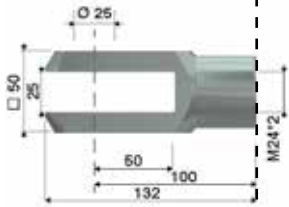

Item	Stroke (+/- 2mm)	EL2 (+/- 2mm)
QS-70-100	100	320
QS-70-200	200	520
QS-70-300	300	720
QS-70-400	400	920
QS-70-500	500	1120
QS-70-600	600	1320
QS-70-700	700	1520
QS-70-800	800	1720

(*) In stock

Diameter piston rod/cylinder: Ø 30mm / Ø 70mm

Valve: integrated - Exhaust screw type «bike»

Fitting: thread piston rod/cylinder: M24*2*35 / M24*2*35

Progressivity: approx. 25%

Speed & damping: normal speed – normal damping over 10 mm

Materials: ceramic treatment on the piston rod (Corrosion resistance 216 h according to DIN 50021 SS) - Black epoxy paint on the cylinder

B24



Load max. 50000N

D24

E24



Load max. 30000N

Rod shroud W24-70

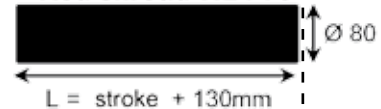

QSI-15 INOX 316L : F₁ from 20 to 400N (F_{2 max} = 500N)

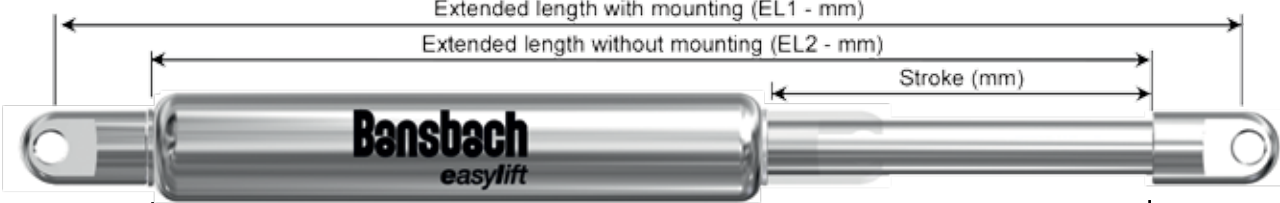



Extended length with mounting (EL1 - mm)
Extended length without mounting (EL2 - mm)
Stroke (mm)

Item	Stroke (+/- 2mm)	EL2 (+/- 2mm)
QSI-15-60 *	60	147
QSI-15-100 *	100	227
QSI-15-150 *	150	327

(*) In stock

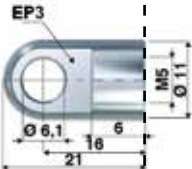
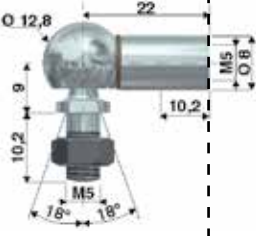
Diameter piston rod/cylinder: Ø 6mm / Ø 15mm
Valve: integrated
Fitting: thread piston rod/cylinder: M5*5 / M5*5
Progressivity: around 27%
Speed & damping: normal speed – high damping
Materials: piston rod and cylinder in stainless steel 316L

Exhaust screw U5

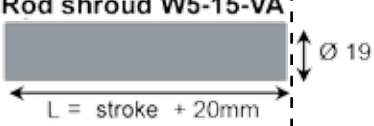

Rod shroud W5-15-VA
Ø 19
L = stroke + 20mm

A5 INOX 316L
Load max. 490N

C5 INOX 303
Load max. 430N

QSI-19 INOX 316L : F₁ from 50 to 700N (F_{2 max} = 930N)

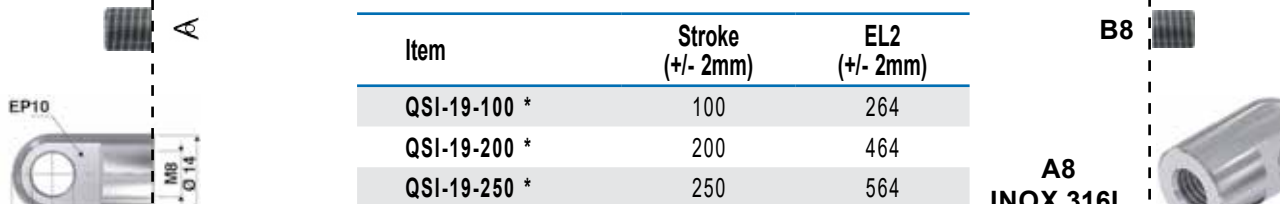



Extended length with mounting (EL1 - mm)
Extended length without mounting (EL2 - mm)
Stroke (mm)

Item	Stroke (+/- 2mm)	EL2 (+/- 2mm)
QSI-19-100 *	100	264
QSI-19-200 *	200	464
QSI-19-250 *	250	564

(*) In stock

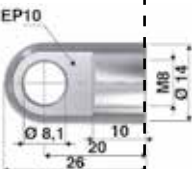
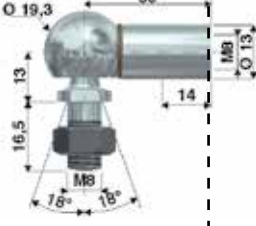
Diameter piston rod/cylinder: Ø 8mm / Ø 19mm
Valve: integrated
Fitting: thread piston rod/cylinder: M8*8 / M8*8
Progressivity: around 33%
Speed & damping: low speed – high damping
Materials: piston rod and cylinder in stainless steel 316L

Exhaust screw U8

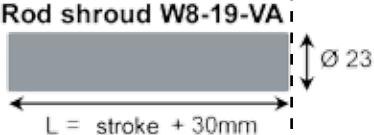

Rod shroud W8-19-VA
Ø 23
L = stroke + 30mm

B8 INOX 316L
Load max. 1560N

C8 INOX 303
Load max. 1430N

QSI-22 INOX 316L : F₁ from 80 to 1300N (F₂ max = 1800N)

Extended length with mounting (EL1 - mm)
Extended length without mounting (EL2 - mm)
Stroke (mm)

Bansbach easylift

Item	Stroke (+/- 2mm)	EL2 (+/- 2mm)
QSI-22-50 *	50	164
QSI-22-100 *	100	264
QSI-22-150 *	150	364
QSI-22-200 *	200	464
QSI-22-250 *	250	564
QSI-22-300 *	300	664
QSI-22-400 *	400	864

(*) In stock

Diameter piston rod/cylinder: Ø 10mm / Ø 22mm
Valve: integrated
Fitting: thread piston rod/cylinder: M8*9 / M8*8
Progressivity: approx. 39%
Speed & damping: low speed – high damping
Materials: piston rod and cylinder in stainless steel 316L

A8 INOX 316L
Load max. 1560N

C8 INOX 303
Load max. 1430N

Exhaust screw U8

Rod shroud W8-22-VA
Ø 28
L = stroke + 30mm

QSIN-22 INOX 304 : F₁ from 80 to 1300N (F₂ max = 1800N)

Extended length with mounting (EL1 - mm)
Extended length without mounting (EL2 - mm)
Stroke (mm)

Bansbach easylift

Item	Stroke (+/- 2mm)	EL2 (+/- 2mm)
QSIN-22-50 *	50	164
QSIN-22-100 *	100	264
QSIN-22-150 *	150	364
QSIN-22-200 *	200	464
QSIN-22-250 *	250	564
QSIN-22-300 *	300	664

(*) In stock

Diameter piston rod/cylinder: Ø 10mm / Ø 22mm
Valve: integrated
Fitting: thread piston rod/cylinder: M8*9 / M8*8
Progressivity: approx. 39%
Speed & damping: low speed – high damping
Materials: piston rod and cylinder in stainless steel 304

A8 INOX 316L
Load max. 1560N

C8 INOX 303
Load max. 1430N

Exhaust screw U8

Rod shroud W8-22-VA
Ø 28
L = stroke + 30mm

All designs, dimensions and specifications are subject to change without notification. (May 2020)

Stainless Steel Gas Spring

QSI-28 INOX 316L : F₁ from 150 to 2500N (F_{2 max} = 3800N)

Item	Stroke (+/- 2mm)	EL2 (+/- 2mm)
QSI-28-100 *	100	262
QSI-28-200 *	200	462
QSI-28-250 *	250	562
QSI-28-300 *	300	662

(*) In stock

Diameter piston rod/cylinder: Ø 14mm / Ø 28mm
Valve: integrated
Fitting: thread piston rod/cylinder: M10*9 / M10*13
Progressivity: around 52%
Speed & damping: low speed – high damping
Materials: piston rod and cylinder in stainless steel 316L

A10 INOX 316L
 Charge max. 3800N

C10 INOX 303
 Charge max. 2500N

Exhaust screw U10

Rod shroud W10-28-VA
 Ø 32
 L = stroke + 40mm

QSIN-28 INOX 304 : F₁ from 150 to 2500N (F_{2 max} = 3800N)

Item	Stroke (+/- 2mm)	EL2 (+/- 2mm)
QSIN-28-100 *	100	262
QSIN-28-200	200	462
QSIN-28-250	250	562
QSIN-28-300 *	300	662

(*) In stock

Diameter piston rod/cylinder: Ø 14mm / Ø 28mm
Valve: integrated
Fitting: thread piston rod/cylinder: M10*9 / M10*13
Progressivity: around 52%
Speed & damping: low speed – high damping
Materials: piston rod and cylinder in stainless steel 304

A10 INOX 316L
 Charge max. 3800N

C10 INOX 303
 Charge max. 2500N

Exhaust screw U10

Rod shroud W10-28-VA
 Ø 32
 L = stroke + 40mm

QZ-19 : F1 from 30 to 330N (F2 max = 390N)

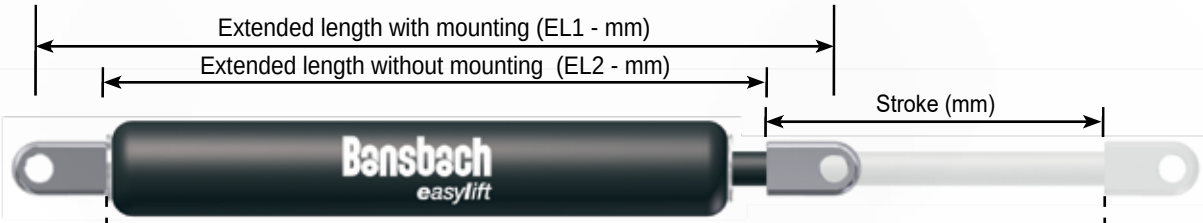

Item	Stroke (+/- 2mm)	EL2 (+/- 2mm)
QZ-19-30	30	112
QZ-19-50 *	50	132
QZ-19-100 *	100	182
QZ-19-150 *	150	232
QZ-19-200 *	200	282
QZ-19-250 *	250	332

(*) In stock

Diameter piston rod/cylinder: Ø 6mm / Ø 19mm
Valve: integrated
Fitting: thread piston rod/cylinder: M8*9 / M8*8
Progressivity: approx. 20%
Speed & damping: normal speed – without damping
Materials: ceramic treatment on the piston rod
 (Corrosion resistance 216 h according to DIN 50021 SS) -
 Black epoxy paint on the cylinder

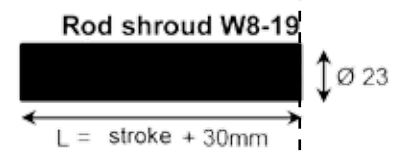
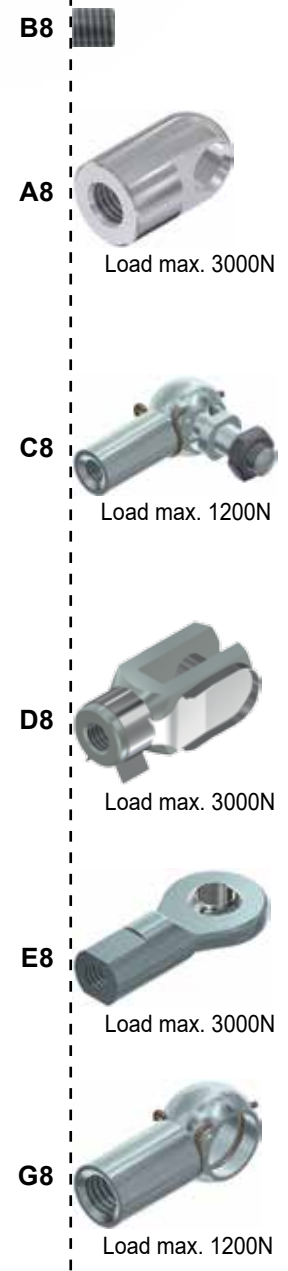
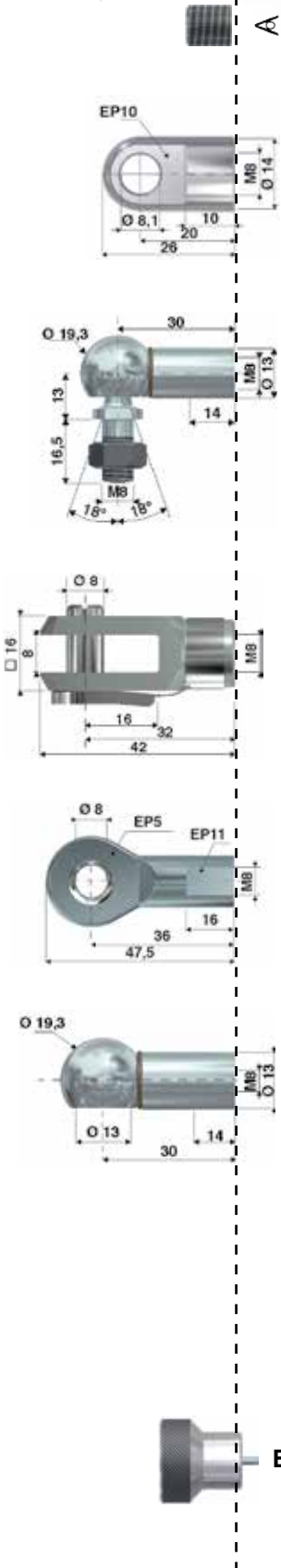

QZ-28 : F₁ from 100 to 1500N (F₂ max = 2400N)

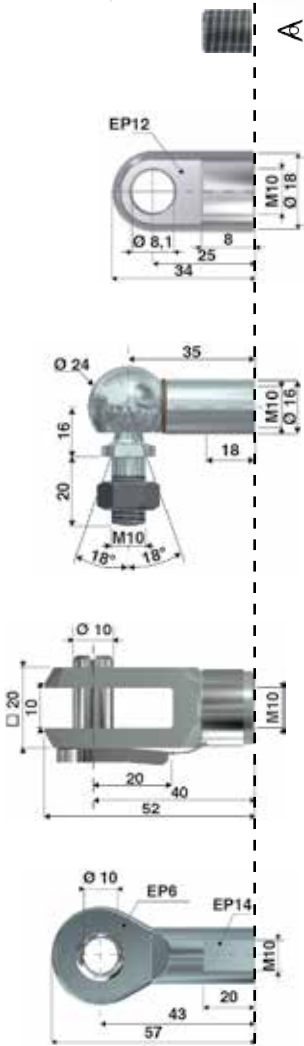
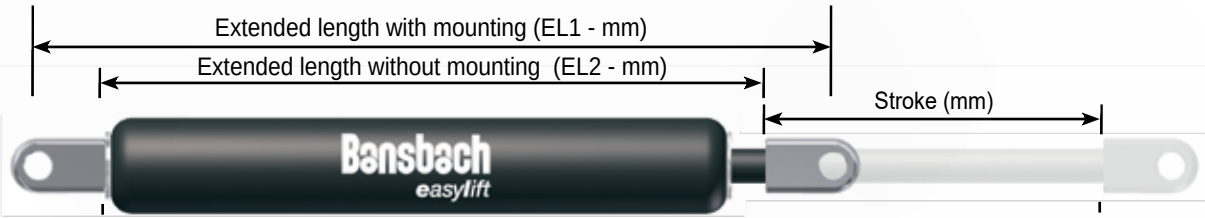

Item	Stroke (+/- 2mm)	EL2 (+/- 2mm)
QZ-28-30	30	130
QZ-28-50 *	50	150
QZ-28-100 *	100	200
QZ-28-150 *	150	250
QZ-28-200 *	200	300
QZ-28-250 *	250	350
QZ-28-300 *	300	400
QZ-28-350 *	350	450
QZ-28-400	400	500
QZ-28-450	450	550
QZ-28-500	500	600
QZ-28-550	550	650
QZ-28-600	600	700
QZ-28-650	650	750

(* In stock)

Diameter piston rod/cylinder: Ø 10mm / Ø 28mm
Valve: integrated
Fitting: thread piston rod/cylinder: M10*9 / M10*13
Progressivity: approx. 60%
Speed & damping: normal speed – without damping
Materials: ceramic treatment on the piston rod
 (Corrosion resistance 216 h according to DIN 50021 SS) -
 Black epoxy paint on the cylinder

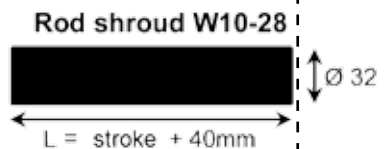

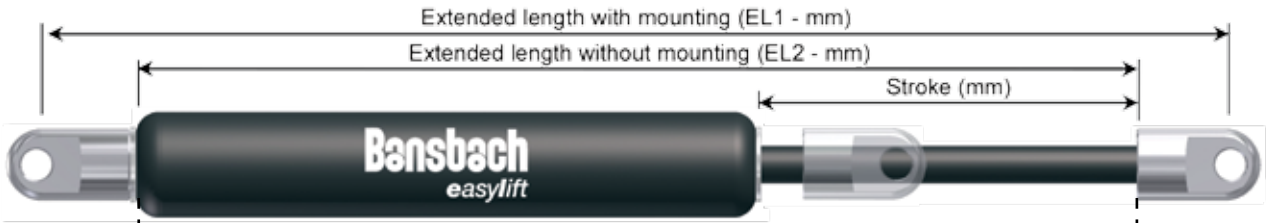

Item	Stroke (+/- 2mm)	EL2 ** (+/- 2mm)	Max. damping in push out direction (N)	Max. damping in pull in direction (N)
QHB-15-25 *	25	90	800	800
QHB-15-50 *	50	140	800	800
QHB-15-75 *	75	190	800	800
QHB-15-100	100	240	350	800
QHB-15-150 *	150	340	300	800

(*) In stock

(**) The speed adjustment system can increase EL1 and EL2 measures up to + 6mm max.

Diameter piston rod/cylinder: Ø 6mm / Ø 15mm

Fitting: thread piston rod/cylinder: M5*5 / M5*5

Materials: ceramic treatment on the piston rod (Corrosion resistance 216 h according to DIN 50021 SS) - Black epoxy paint on the cylinder

Control Type:
 «B» = dual effect
 «A» = pull direction
 «E» = push direction

Free travel effect: 20 % of the stroke

Option: «without free travel effect» (with floating piston) on request
 Please note «Y/xxN» where «xx» is the force at the end of the item
 EL2 = stroke x 2,45 + 47 (max. force = 50N)

Adjustment: only possible when the piston rod is in its entirety in or out (in case of model with «Y» option, only piston rod in out position)

1. Hold the cylinder in one hand and the piston rod with the other
2. Adjust the damper by turning the piston rod. For an adjustment piston rod in «out position», pull slowly the piston rod and turn it in the same time in order to hook the piston. For an adjustment piston rod in «in position», push slowly the piston rod and turn it in the same time in order to hook the piston.
3. Warning: Don't used pliers to manipulate the piston rod at the risk of damage it and create a leak.

Turn on the right side :
 Increase the control,
 speed lower.

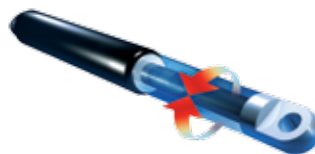

Turn on the left side:
 Decrease the control,
 speed faster.

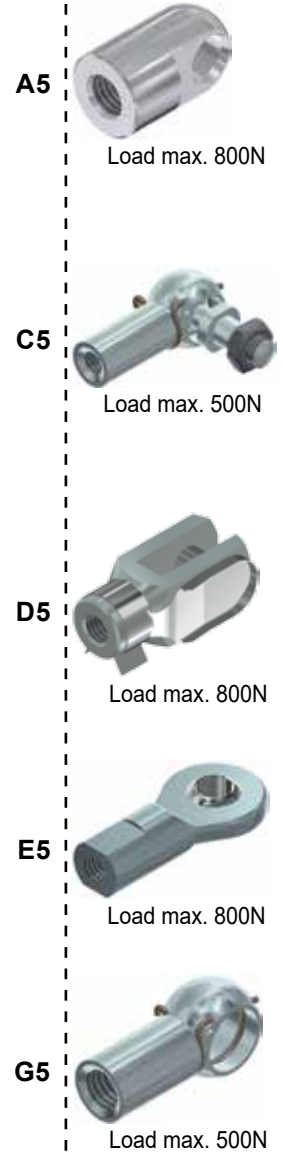
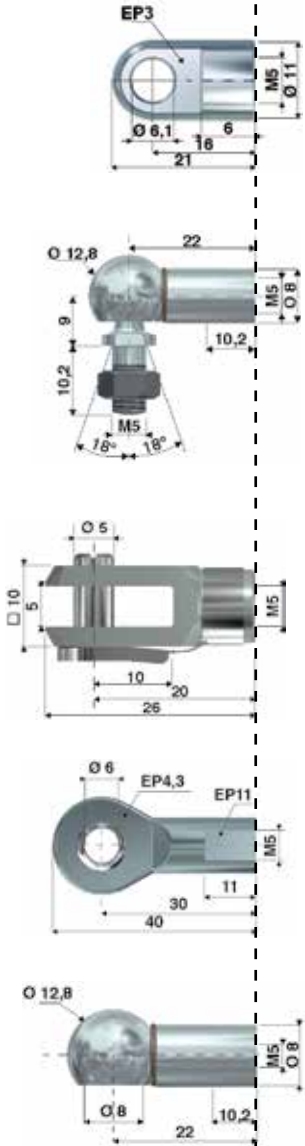
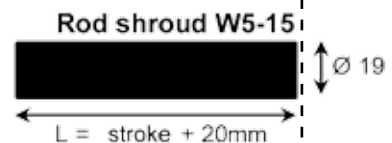

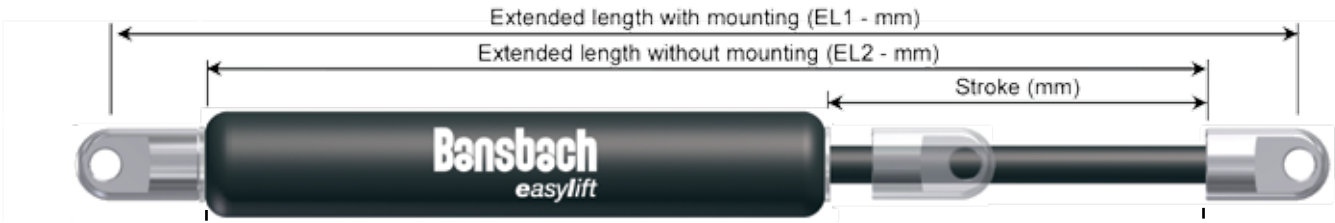

Item	Stroke (+/- 2mm)	EL2 ** (+/- 2mm)	Max. damping in push out direction (N)	Max. damping in pull in direction (N)
QHB-22-50	50	150	1800	1800
QHB-22-100 *	100	250	1800	1800
QHB-22-150 *	150	350	1800	1800
QHB-22-200 *	200	450	1000	1800
QHB-22-250	250	550	1000	1800

(*) In stock

(**) The speed adjustment system can increase EL1 and EL2 measures up to + 6mm max.

Diameter piston rod/cylinder: Ø 8mm / Ø 22mm

Fitting: thread piston rod/cylinder: M8*9 / M8*8

Materials: ceramic treatment on the piston rod (Corrosion resistance 216 h according to DIN 50021 SS) - Black epoxy paint on the cylinder

Control Type: «B» = dual effect
«A» = pull direction
«E» = push direction

Free travel effect: 20 % of the stroke

Option: «without free travel effect» (with floating piston) on request
Please note «Y/xxN» where «xx» is the force at the end of the item
EL2 = stroke x 2,38 + 55 (max. force = 50N)

Adjustment: only possible when the piston rod is in its entirety in or out (in case of model with «Y» option, only piston rod in out position)

1. Hold the cylinder in one hand and the piston rod with the other
2. Adjust the damper by turning the piston rod. For an adjustment piston rod in «out position», pull slowly the piston rod and turn it in the same time in order to hook the piston. For an adjustment piston rod in «in position», push slowly the piston rod and turn it in the same time in order to hook the piston.
3. Warning: Don't used pliers to manipulate the piston rod at the risk of damage it and create a leak.

Turn on the right side :
Increase the control,
speed lower.

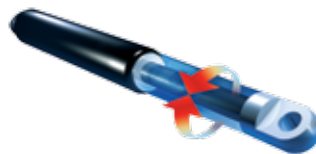

Turn on the left side:
Decrease the control,
speed faster.

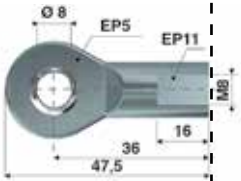
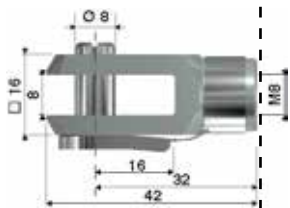
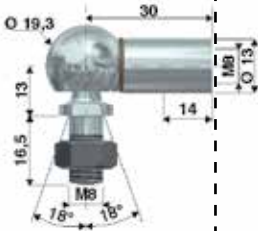
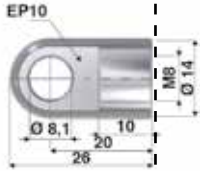
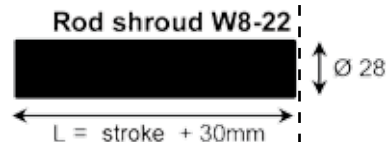

A8



Load max. 3000N

C8



Load max. 1300N

D8



Load max. 3000N

E8



Load max. 3000N

G8



Load max. 1300N

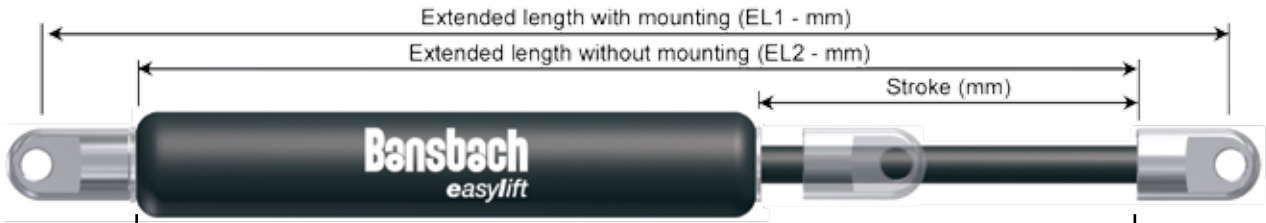

Item	Stroke (+/- 2mm)	EL2 ** (+/- 2mm)	Max. damping in push out direction (N)	Max. damping in pull in direction (N)
QHB-28-100 *	100	260	3000	3000
QHB-28-150 *	150	360	3000	3000
QHB-28-200	200	460	3000	3000
QHB-28-250	250	560	3000	3000
QHB-28-300 *	300	660	2500	3000
QHB-28-350	350	760	2000	3000
QHB-28-400	400	860	1500	3000
QHB-28-500	500	1060	1000	3000

(*) In stock

(**) The speed adjustment system can increase EL1 and EL2 measures up to + 6mm max.

Diameter piston rod/cylinder: Ø 10mm / Ø 28mm

Fitting: thread piston rod/cylinder: M8*9 / M8*8

Materials: ceramic treatment on the piston rod (Corrosion resistance 216 h according to DIN 50021 SS) - Black epoxy paint on the cylinder

Control Type: «B» = dual effect
«A» = pull direction
«E» = push direction

Free travel effect: 20 % of the stroke

Option: «without free travel effect» (with floating piston) on request
Please note «Y/xxN» where «xx» is the force at the end of the item
EL2 = stroke x 2,35 + 60 (max. force = 100N)

Adjustment: only possible when the piston rod is in its entirety in or out (in case of model with «Y» option, only piston rod in out position)

1. Hold the cylinder in one hand and the piston rod with the other
2. Adjust the damper by turning the piston rod. For an adjustment piston rod in «out position», pull slowly the piston rod and turn it in the same time in order to hook the piston. For an adjustment piston rod in «in position», push slowly the piston rod and turn it in the same time in order to hook the piston.
3. Warning: Don't used pliers to manipulate the piston rod at the risk of damage it and create a leak.

Turn on the right side :
Increase the control,
speed lower.

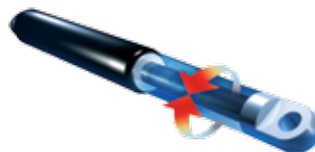

Turn on the left side:
Decrease the control,
speed faster.

Rod shroud W8-28

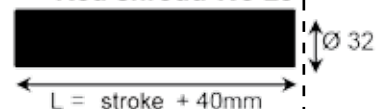

A8

Load max. 3000N



C8

Load max. 1300N



D8

Load max. 3000N



E8

Load max. 3000N



Load max. 1300N

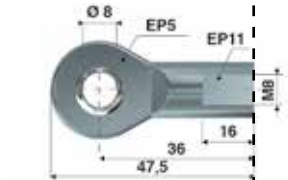
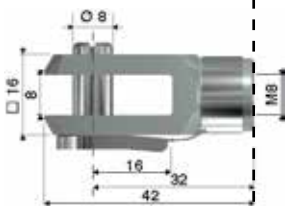
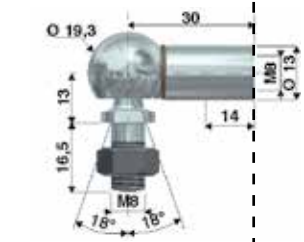
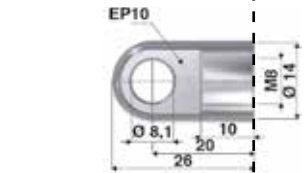



Item	Stroke (+/- 2mm)	EL2 ** (+/- 2mm)	Max. damping in push out direction (N)	Max. damping in pull in direction (N)
QHB-40-100	100	275	10000	10000
QHB-40-150 *	150	375	10000	10000
QHB-40-200	200	475	10000	10000
QHB-40-300	300	675	10000	10000
QHB-40-400	400	875	8000	10000
QHB-40-500	500	1075	6000	10000
QHB-40-600	600	1275	4000	10000
QHB-40-700	700	1475	3000	10000
QHB-40-800	800	1675	3000	10000

(*) In stock

(**) The speed adjustment system can increase EL1 and EL2 measures up to + 6mm max.

Diameter piston rod/cylinder: Ø 14mm / Ø 40mm

Fitting: thread piston rod/cylinder: M14*15 / M14*15

Materials: ceramic treatment on the piston rod
(Corrosion resistance 216 h according to DIN 50021 SS) - Black epoxy paint on the cylinder

Control Type: «B» = dual effect
«A» = pull direction
«E» = push direction

Free travel effect: 20 % of the stroke

Option: «without free travel effect» (with floating piston) on request

Please note «Y/xxN» where «xx» is the force at the end of the item

EL2 = stroke x 2,32 + 82 (max. force = 200N)

Adjustment: only possible when the piston rod is in its entirety in or out (in case of model with «Y» option, only piston rod in out position)

1. Hold the cylinder in one hand and the piston rod with the other
2. Adjust the damper by turning the piston rod. For an adjustment piston rod in «out position», pull slowly the piston rod and turn it in the same time in order to hook the piston. For an adjustment piston rod in «in position», push slowly the piston rod and turn it in the same time in order to hook the piston.
3. Warning: Don't used pliers to manipulate the piston rod at the risk of damage it and create a leak.

Turn on the right side :
Increase the control,
speed lower.

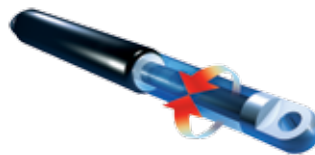

Turn on the left side:
Decrease the control,
speed faster.

Rod shroud W14-40

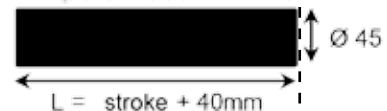

A14

Load max. 10000N



C14

Load max. 3000N



D14

Load max. 10000N



E14

Load max. 8000N

Accessories can be ordered separately.

Combine
individually

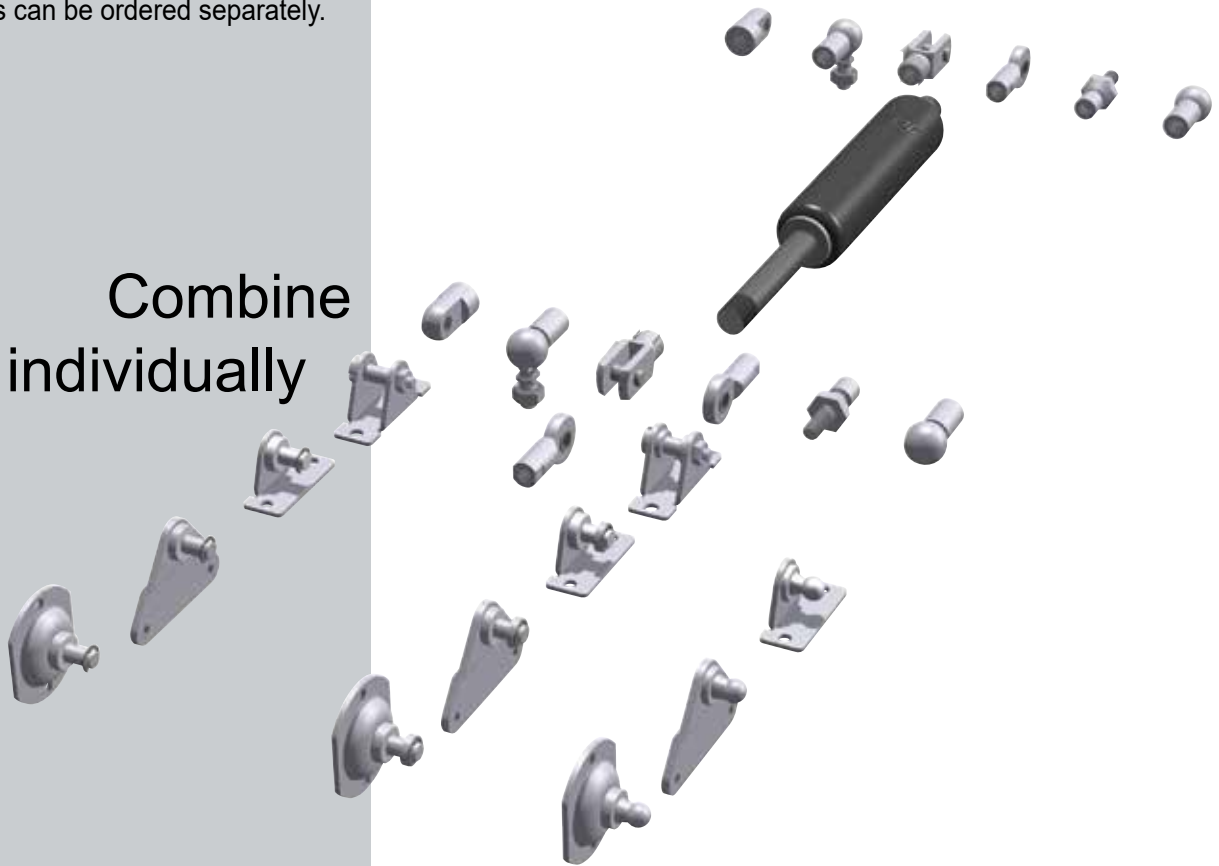

Accessories	23
Stainless Steel Accessories	25
Force adjustment	26
Instruction manual	27

QS-8 / QS-10 / QS-12

<p>¹ Load max. 180 N</p>	<p>NA3,5</p>	<p>NG3,5</p>	<p>¹ Load max. 180 N</p>	<p>OA3,5</p>	<p>OG3,5</p>
-------------------------------------	--------------	--------------	-------------------------------------	--------------	--------------

QS-15 / QHB-15

<p>¹ Load max. 500 N</p>	<p>MA5</p>	<p>¹ Load max. 400 N</p>	<p>NA5</p>	<p>NG5</p>	
<p>¹ Load max. 180 N</p>	<p>OA5</p>	<p>OG5</p>	<p>¹ Load max. 500 N</p>	<p>PA5</p>	<p>PG5</p>

QS-19 / QS-22 / QZ-19 / QHB-22 / QHB-28

<p>¹ Load max. 1800 N</p>	<p>MA8</p>	<p>ME8</p>	<p>¹ Load max. 1000 N</p>	<p>NA8</p>	<p>NE8</p>	<p>NG8</p>	
<p>¹ Load max. 1200 N</p>	<p>OA8</p>	<p>OE8</p>	<p>OG8</p>	<p>¹ Load max. 1200 N</p>	<p>PA8</p>	<p>PE8</p>	<p>PG8</p>

QS-28 / QZ-28

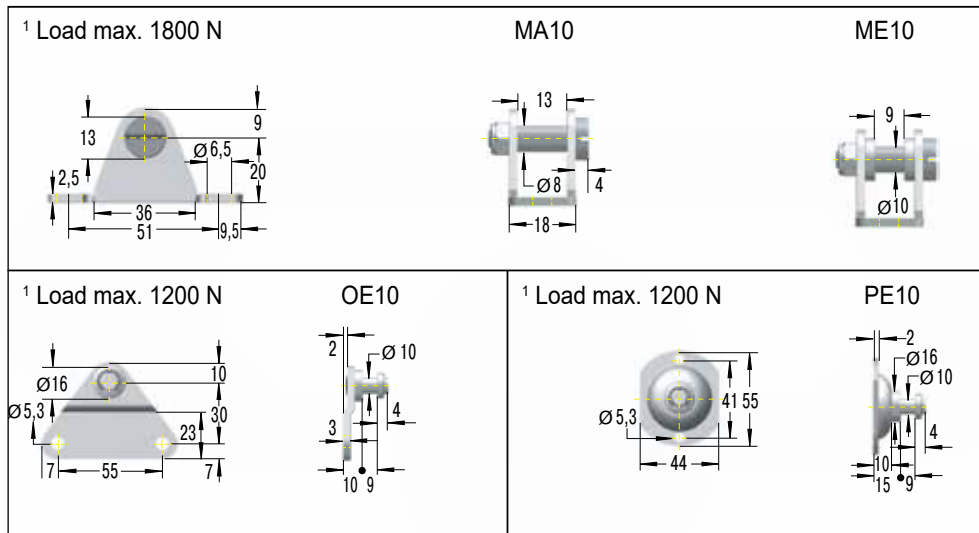

QS-40 / QHB-40

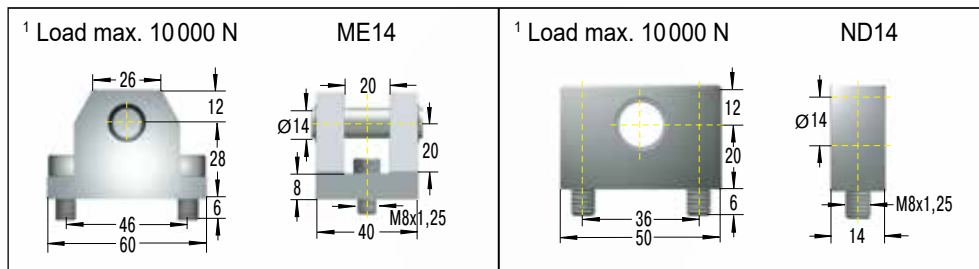

QS-70

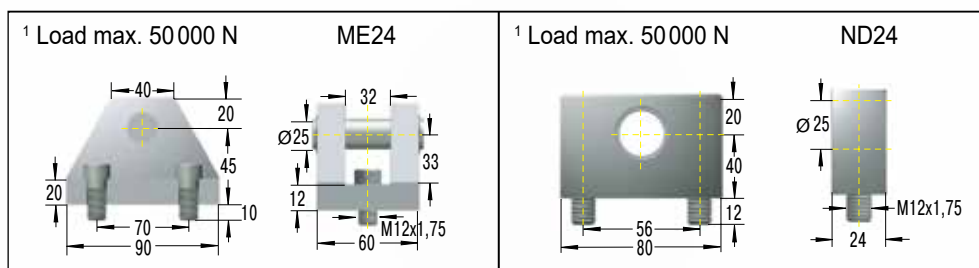

QSI-15

<p>¹ Load max. 500 N</p> <p style="text-align: center;">MA5-V4A</p>	<p>¹ Load max. 400 N</p> <p style="text-align: center;">NA5-V4A</p>	<p>¹ Load max. 400 N</p> <p style="text-align: center;">NG5-V4A</p>	
<p>¹ Load max. 180 N</p> <p style="text-align: center;">OA5-V4A</p>	<p>¹ Load max. 180 N</p> <p style="text-align: center;">OG5-V4A</p>	<p>¹ Load max. 500 N</p> <p style="text-align: center;">PA5-V4A</p>	<p>¹ Load max. 500 N</p> <p style="text-align: center;">PG5-V4A</p>

QSI-19 / QSI-22 / QSIN-22

<p>¹ Load max. 1800 N</p> <p style="text-align: center;">MA8-V4A</p>	<p>¹ Load max. 1000 N</p> <p style="text-align: center;">NA8-V4A</p>	<p>¹ Load max. 1000 N</p> <p style="text-align: center;">NG8-V4A</p>	
<p>¹ Load max. 1200 N</p> <p style="text-align: center;">OA8-V4A</p>	<p>¹ Load max. 1200 N</p> <p style="text-align: center;">OG8-V4A</p>	<p>¹ Load max. 1200 N</p> <p style="text-align: center;">PA8-V4A</p>	<p>¹ Load max. 1200 N</p> <p style="text-align: center;">PG8-V4A</p>

QSI-28

<p>¹ Load max. 1800 N</p> <p style="text-align: center;">MA10-V4A</p>

All designs, dimensions and specifications are subject to change without notification. (May 2020)

FILLING CASE



The Bansbach filling case offers you the possibility of filling the gas springs on site or adjusting the force specifically to your application. The filling kit includes all the parts you need to inflate your gas springs. A very precise filling of the gas springs is possible with the use of the digital manometer model.

The table for determining the charge pressure is included in the case. Only the nitrogen bottle is not included but the kit includes a connection type G3W21.8X1/14 for fixing on the standard thread.

In the case of a project with serial production, the gas spring inflated by you must be returned to us in order to measure the force on our calibrated bench.

MEASURING AND DEFLATING CASE



The Bansbach measuring and deflation case allows you to check the pressure inside your gas springs. The determination table will help you to define the force of each cylinder.

This equipment, integrating a digital manometer, also allows controlled deflation of the gas springs in order to adjust them to the desired force. After this manoeuvre, you will not be able to inflate the gas spring again.

This material is particularly appreciated by our customers who have gas springs with the same stroke but with different forces. Indeed, Bibus France offers you gas springs inflated to the maximum value of the application and your technical services have the possibility to deflate according to their needs.

PROCEDURE FOR DEFLATING A GAS SPRING USING A U-TYPE SCREW

1. Hold the gas spring piston rod down.
2. Remove the connecting part from the threaded part of the cylinder.
3. Screw the exhaust screw onto the threaded part of the cylinder. When you feel resistance, proceed slowly and carefully. This opens the valve and you can hear the nitrogen escape and reduce the pressure. Turn the exhaust screw back immediately to avoid excessive nitrogen loss.
4. After adjustment, remove the exhaust screw, tighten the connecting part and test the gas spring in the application. Repeat if necessary.

! If you use 2 gas springs in parallel, each of them must have the same force to avoid imbalance and create radial stresses in the application. If the gas spring is too deflated, you can return it to us for a pressure re-installation (you can consult our price list for this operation).

If it is a gas spring mounted on a prototype, you can return it to us to measure its force; then we can supply the other gas spring of the series to the same setting.

If a gas spring is damaged or worn, it is neither repairable nor re-inflatable.

IMPORTANT ADVICE FOR GAS SPRING INSTALLATION

1. Bansbach gas springs will operate in surrounding temperatures from -30°C to +80°C. We can equip our springs with special seals to withstand temperatures as low as -55°C or as high as +200°C. Gas springs should not be overheated or put in open fire!
2. Gas springs are filled with pure nitrogen. Nitrogen is an inert gas, which does not burn, will not explode and is not poisonous. **But: Gas springs have very high internal pressure (up to approx. 300 bar). Do not open without instruction!**
3. Disposal/Recycling: Gas springs consist mostly of metal and can be recycled, but first the gas spring must be pressureless.
4. All gas springs are labeled with the warning „Do not open, high pressure“, the force, the part number and the production date. If these data are unreadable, we refuse the liability for damages which result from this fact. Warranties aren't possible anymore. Double labelling is possible if the force is changed by BIBUS. Only the BIBUS label is valid for the force value.
5. Bansbach gas springs can be used generally as a limit stop in both directions. The occurring forces should not exceed the following approximate values.

Size	Force Max.
4/12	2500 N
6/15	4000 N
6/15 Stainless Steel	2000 N
8/19 and 8-10/22	7000 N
8/19 and 10/22 Stainless Steel	3000 N

Size	Force Max.
10-12-14/28	10000 N
10/28 and 14/28 Stainless Steel	8000 N
14-20/40	20000 N
14-20/40 Stainless Steel	15000 N

Note: This isn't valid for lockable gas springs and traction springs!

Attention: The figures refer to the average pressure range of the respective size. Some connectors such as elbow joints may not be suitable for the above values.

6. Gas springs should be installed with the piston rod downwards. This position ensures the best damping effect. Only Bansbach gas springs include an integrated grease chamber which allows different directions of installation.
7. Gas springs should not be exposed to any tilting or side forces during operation. If this is unavoidable, please check the installation and use suitable connecting parts.
8. For lockable models, the trigger control setting is important to ensure correct operation. The trigger piston rod must therefore be fully actuated (up to the level of the main piston rod) in order to avoid incomplete valve opening which would result in reduced speed, increased actuating force and risk of internal cylinder damage. The adjustment of the push button on the piston rod and the cable tension, for controls of this type, are important to check before the start of using. The controls offered are made for manual action, so for limited effort. In the case of a different actuation, it must be confirmed that the force applied on the each component of the control remains low, without radial force, otherwise damage may occur.
9. Gas springs are maintenance free. Do not grease or oil the piston rod.
10. The piston rod must not be painted and should be protected against shocks, scratches and dirt as well as against aggressive and corrosive media. The cylinder should not be deformed. Any such damage will destroy the sealing system.
11. Bansbach gas springs usually can be stored in any position. Pressure loss through long storage is not to be expected. There are no negative values known, but there may be a sticking effect the first time you compress a spring, which may require a higher expenditure of force the first time (initial break - away force).
12. Warranty claims expire latest 1 year from date of production. Manufacturing mistakes and/or quality defects are immediately noticeable. If you are unhappy for any reason with the delivered quality, we ask you to return the springs immediately. Your complaint and a copy of the original invoice must be enclosed.
13. **IMPORTANT:** Bansbach gas springs which mostly consist of parts held in stock – are produced due to customer's orders. A cancellation, modification afterwards, change or refusal is therefore not possible.
14. Bansbach gas springs are built and tested for highest requirements and highest reliability. Installation advices as well as our comprehensive advice will help you in choosing your gas springs. **But: The examination of the suitability for the respective application has to be executed by the customer!** You aren't allowed to use in this application not suitable and faulty products. We can not assume any liability for the function and the lifetime of your final product.
15. You can select your best dimensions yourself, within the mentioned limits. The tolerance for the lengths is generally deemed to be $\pm 2,5$ mm; in series production, there is a tolerance of max. ± 1 mm. If very high demands are placed on durability and stability, please avoid the combination of small diameter + long stroke + high force.
16. Damping characteristics can create vibrations which lead to a resonator within the application and may cause noise. Little changes concerning the installation or the attachments may help to avoid them.
17. Compliant with RoHS and WEEE regulations and Directives 2003/11/EC, 2002/96/EG. Not subject to Directives 94/9/EG, 97/23/EG, 98/37/EG, UN3164, TRGS220 and UL60601-1. Our customers and users are responsible for checking whether the use of Bansbach gas springs in the end product respect national and international laws and regulations.

ENGINEERING
LOGISTICS
SERVICES

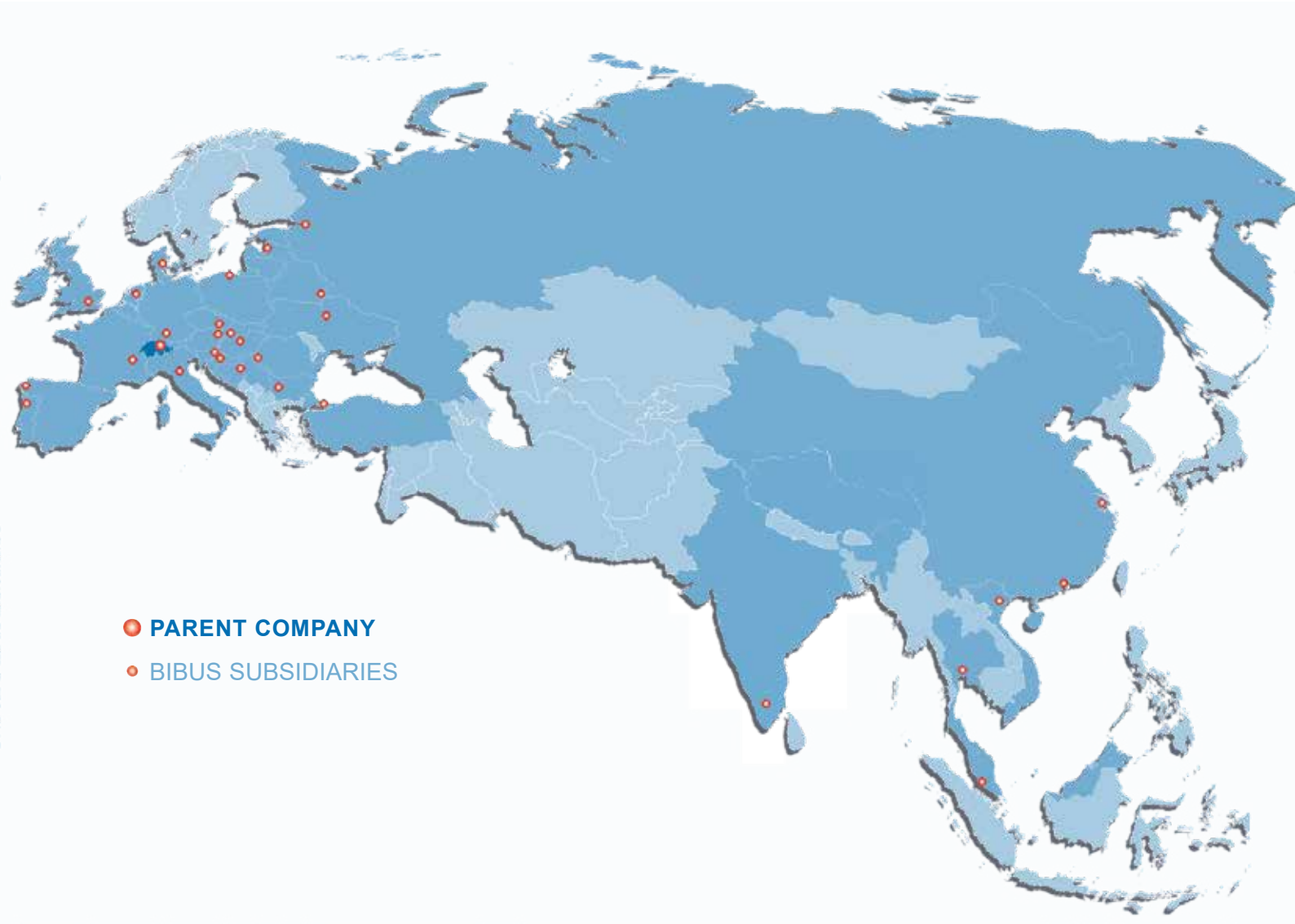

- PARENT COMPANY
- BIBUS SUBSIDIARIES

BIBUS (Thailand) Co., Ltd
181/68 Soi Nuanchan 32
Buengkhum District
10230 Bangkok
THAILAND

Phone +66 90 894 98 67
Fax +66 2 054 65 76

info@bibus.co.th
www.bibus.co.th