

Technical Information

# PLUS+1<sup>®</sup> HMI Peripherals

## HMR CAN Rotary Input Device



**Revision history**

*Table of revisions*

<b>Date</b>	<b>Changed</b>	<b>Rev</b>
July 2018	Corrected reference literature titles	0103
June 2018	Corrected title	0102
June 2018	First edition	0101

## Contents

### HMR literature references

Technical Information (TI).....	4
Data Sheet (DS).....	4
API Specifications (API).....	4
PLUS+1® GUIDE User Manual.....	4
Latest version of technical literature.....	4

### User liability and safety statements

OEM responsibility.....	5
-------------------------	---

### Overview

PLUS+1® HMI Peripherals.....	6
HMR CAN Rotary Input Device.....	6
Features.....	6

### Ordering information

Model variants.....	7
Model code.....	7
Model code key.....	7
Related products.....	8

### Product ratings

Electronic components environmental testing criteria.....	9
Specifications.....	10
Ingress Protection (IP) rating .....	10

### Color and command options

Indicator and backlight color options.....	11
Indicator and backlight command options.....	12

### CAN messaging protocol

J1939.....	13
HMR transmitted Message Structure.....	14
HMR configuration Message Structure.....	14
Command values.....	15
J1939 proprietary messages.....	15
LED brightness.....	15
Backlight LEDs.....	15
LEDs.....	16
Blink rate and indicator configuration for buttons.....	16
Blink rate and indicator configuration for rotary.....	16
Rotary encoder configuration.....	17

### Installation and start-up

Dimensions.....	18
Mounting.....	18
Connectors.....	19
Pin assignments.....	19
Machine wiring guidelines.....	19
Machine welding guidelines.....	20

## HMR literature references

### Reference literature

Literature title	Literature type	Literature number
PLUS+1° HMI Peripherals — HMR CAN Rotary Input Device	Technical Information	BC00000397
PLUS+1° HMI Peripherals — HMR CAN Rotary Input Device	Data Sheet	AI00000327
PLUS+1° GUIDE Software	User Manual	AQ00000026

### Technical Information (TI)

A TI is comprehensive information for engineering and service personnel to reference.

### Data Sheet (DS)

A DS is summarized information and parameters that are unique to a specific model.

### API Specifications (API)

An API is specifications for programming variable settings.

---

[API specifications are the definitive source of information regarding pin characteristics.](#)

---

### PLUS+1° GUIDE User Manual

The Operation Manual (OM) details information regarding the PLUS+1° GUIDE tool used in building PLUS+1° applications. This OM covers the following broad topics:

- How to use the PLUS+1° GUIDE graphical application development tool to create machine applications
- How to configure module input and output parameters
- How to download PLUS+1° GUIDE applications to target PLUS+1° hardware modules
- How to upload and download tuning parameters
- How to use the PLUS+1° Service Tool

### Latest version of technical literature

---

Danfoss product literature is online at: [www.danfoss.com](http://www.danfoss.com)

---

## **User liability and safety statements**

### **OEM responsibility**

The OEM of a machine or vehicle in which Danfoss products are installed has the full responsibility for all consequences that might occur. Danfoss has no responsibility for any consequences, direct or indirect, caused by failures or malfunctions.

- Danfoss has no responsibility for any accidents caused by incorrectly mounted or maintained equipment.
- Danfoss does not assume any responsibility for Danfoss products being incorrectly applied or the system being programmed in a manner that jeopardizes safety.
- All safety critical systems shall include an emergency stop to switch off the main supply voltage for the outputs of the electronic control system. All safety critical components shall be installed in such a way that the main supply voltage can be switched off at any time. The emergency stop must be easily accessible to the operator.

## Overview

### PLUS+1® HMI Peripherals

Danfoss HMI Peripherals are an expansion of the PLUS+1® family of mobile machine management products.

### HMR CAN Rotary Input Device

The HMR CAN Rotary Input Device brings screen navigation closer to the operator, allowing “blind operation” and minimizing the need to reach for buttons/dials/touch-screen on the display during operation. The back-lit buttons can be used as hot keys to quickly navigate to a screen or used for machine functions, while the indicator bars on each button provide optical feedback to the operator

The HMR has been optimized for ergonomic, five finger control. The seven large buttons are available with standard icons, or customizable to meet application needs. Each button features RGB LEDs for backlight and light bars that are controllable via CAN messaging, with adjustable light intensity. The rotary knob encompasses an eighth push button and includes RGB LED lighting at the base.

The HMR features robust mechanical, electrical, and Ingress Protection specifications that meet the demands of mobile machine operation. It is suitable for installation in open and enclosed cabs.

## Features

- Seven large configurable push buttons
- Hall effect rotary dial, with 32 detents/revolution and additional push button inside
- Back-lit buttons with standard or customizable icons
- All LEDs are RGB: Buttons Backlights, Indicator Bar and Rotary Backlight
- PLUS+1® GUIDE configurable
- CAN J1939
- Rugged IP66 and IP67 ratings
- Integrated DEUTSCH connector
- CE compliant, E1 E-Mark (pending) and ROHS compliant
- Optional hand-rest (future development or customer-created for application needs)
- Button and Rotary Life: 1 Million Cycles

## Ordering information

### Model variants

Part number	Order code	Description
11217428	HMR-111-00-1-0-0-0-0	HMR, No Graphics, LED Indicators
11202900	HMR-111-00-1-0-1-0-0	HMR, Number Graphics, LED Indicators
11202899	HMR-111-00-1-0-2-0-0	HMR, Navigation Graphics, LED Indicators
11217427	HMR-111-00-1-1-1-0-0	HMR, Number Graphics, LED Indicators, Danfoss Logo
11217426	HMR-111-00-1-1-2-0-0	HMR, Navigation Graphics, LED Indicators, Danfoss Logo

### Model code

A			B			C		D	E	F	G	H
H	M	R										

### Model code key

A—Model name	Description
HMR	HMR CAN Rotary Input Device, PLUS+1® HMI Peripherals

B—LED lights	Description
111	Indicator bar, back-light, and knob LEDs (RGB)

C—PCBA / Special features	Description
00	HMR, version 0

D—Rotary knob configuration	Description
1	Standard ring-style knob

E—Knob logo	Description
0	No logo
1	Danfoss logo
2	Generic <b>Your Logo Here</b> logo
9	Custom logo

F—Button graphic configuration	Description
0	No graphics (blank)
1	Number graphics
2	Navigation graphics
8	ISO graphics
9	Custom graphics

G—Special features (software)	Description
0	No special software features
9	Custom configuration file

H—Hand-rest option	Description
0	No hand-rest
9	Custom hand-rest

**Ordering information**

**Related products**

4 pin mating connector	Part number
DEUTSCH 4 PIN Connector Kit	11028348



## Product ratings

### Electronic components environmental testing criteria

#### *Climate environment*

Description	Applicable standard	Comment
Storage temperature	IEC 60068-2-1, test Ab, IEC 60068-2-2 test Bb	
Operating temperature	IEC 60068-2-1, test Ab, IEC 60068-2-2 test Bd	
Thermal cycle	IEC 60068-2-2, test Na, IEC 60068-2-38 (partial)	
Humidity	IEC 60068-2-78, IEC 60068-2-30 test Db	Damp heat steady state and cyclic.
Degree of protection	IEC 60529	

#### *Chemical environment*

Description	Applicable standard	Comment
Salt mist	IEC 60068-2-58 test Kb	
Chemical resistance	ISO 16750-5	

#### *Mechanical environment*

Description	Applicable standard	Comment
Vibration	IEC 60068-2-6 test Fc, IEC6008-2-64 test Fh	
Bump	IEC 60068-2-29 test Eb	
Shock	IEC 60068-2-27 test Ea	
Free fall	IEC 60068-2-32 test Ed	

#### *Electrical/electromagnetic*

Description	Applicable standard	Comment
EMC emission	ISO 13766, SAE J1113-13	Electromagnetic compatibility for earth moving machinery.
EMC immunity	ISO 13766	Electromagnetic compatibility for earth moving machinery.
Electrostatic discharge	EN 60-1 000-4-2	
Auto electrical transients	ISO 7637-2, ISO 7637-3	
Short circuit protection	Danfoss test	Inputs and outputs survive continuous short circuit. Normal function resumes when short is removed.
Reversed polarity protection	Danfoss test	Survives reverse polarity at supply voltage for at least five minutes.

## Product ratings

### Specifications

#### Characteristics

<b>Processor</b>	ARM Cortex M3, 32 bit, 120 MHz
<b>RAM</b>	64 kB
<b>EEPROM</b>	32 kB
<b>Supply voltage</b>	9 to 36 V <sub>DC</sub>
<b>Connector</b>	DEUTSCH DT-4
<b>IP rating (with mating connector attached)</b>	IP66 and IP67
<b>Operating temperature</b>	-40°C to +85°C [-40°F to 185°F]
<b>Storage temperature</b>	-40°C to +85°C [-40°F to 185°F]
<b>Weight</b>	0.159 kg [0.351 lb]
<b>Vibration/Shock</b>	IEC 60068-2-64 (7.67g) /2-27 (50g)
<b>EMI/RFI rating</b>	100 V/M
<b>Humidity</b>	IEC 60068-2-78, 60068-2-30
<b>Transients</b>	ISO 7637/1, 2, 3
<b>Button Cycle Life</b>	1 Million Cycles
<b>Rotary Dial Cycle Life</b>	1 Million Cycles

### Ingress Protection (IP) rating

---

HMR CAN Rotary Input Device carries a full Ingress Protection rating of IP 67.

---

## Color and command options

The HMR offers various color and command option for application specific customization.

- Each of the buttons has 2 Indicator LEDs located on the edge of the unit. Each one of these has an Enable signal - they share the RGB signals.
- Each of the buttons has 2 backlight LEDs paired together sharing the RGB signals.
- The rotary encoder has a group of 6 backlights that can be configured.

## Indicator and backlight color options

### Indicator default colors

Index	Default color	R	G	B
0	Green	0	0xFFFF	0
1	Yellow	0xFFFF	0xFFFF	0
2	Red	0xFFFF	0	0
3	White	0xFFFF	0xFFFF	0xFFFF
4	Cyan	0	0xFFFF	0xFFFF
5	Blue	0	0	0xFFFF
6	Magenta	0xFFFF	0	0xFFFF
7	Black	0	0	0
8	Dark Blue	0x1919	0x1919	0x7070
9	Purple	0x5454	0x1919	0x6D6D
10	Amber	0xFFFF	0xBFBF	0
11	Maroon	0xFFFF	0CCCCC	0x3333
12	Teal	0x3838	0x8E8E	0x8E8E
13	Light Blue	0x8787	0xCECE	0xFAFA
14	Dark Green	0	0x6464	0
15	Light Green	0x3C3C	0xB3B3	0x7171

### Backlight default colors

Index	Default color	R	G	B
0	White	0xFFFF	0xFFFF	0xFFFF
1	Green	0	0xFFFF	0
2	Red	0xFFFF	0	0
3	Blue	0	0	0xFFFF
4	Cyan	0	0xFFFF	0xFFFF
5	Yellow	0xFFFF	0xFFFF	0
6	Magenta	0xFFFF	0	0xFFFF
7	Black	0	0	0
8	Dark Blue	0x1919	0x1919	0x7070
9	Purple	0x5454	0x1919	0x6D6D
10	Amber	0xFFFF	0xBFBF	0
11	Maroon	0xFFFF	0CCCCC	0x3333
12	Teal	0x3838	0x8E8E	0x8E8E
13	Light Blue	0x8787	0xCECE	0xFAFA
14	Dark Green	0	0x6464	0
15	Light Green	0x3C3C	0xB3B3	0x7171

### Color and command options

#### Indicator and backlight command options

Mode	Allowed speeds	Allowed phases
Off	N/A	N/A
On	N/A	N/A
Flashing	Low Medium High	Normal Inverted
Breathing	Low Medium High	Normal Inverted

## CAN messaging protocol

### J1939

The system supports various types of J1939 messaging, using J1939 compliant baud rates in the following ranges.

Description	Unit	Minimum	Maximum	Typical	Comment
Available Baud rates	kbps			50	The default baud rate is 250 kbit.
				100	
				125	
				250	
				500	
				1000	

The system performs an address claim per J1939-73 and provide programmable name for various fields in address claim.

*Programmable name for various fields*

Name field	Default	Customer configurable	Comment
ECU Instance	1	Yes	
Function Instance	0	Yes	
Function	135	Yes	Keypad
Vehicle System	0	Yes	Non-specific
Vehicle System Instance	1	Yes	
Industry Group	0	Yes	Global

## CAN messaging protocol

### HMR transmitted Message Structure

The system default shall utilize a standard AUXIO1 message from J1939-71 to send the button and encoder status.

**DiffCount** Differential count provides the count of rotary ticks since the last message. Turning clockwise provides positive incrementation, counter-clockwise negative.

**AbsCount** Absolute count, since power up, tracks between start value and max value. If rollover is enabled, AbsCount keeps track of counts until a max value is reached then rolls over to start value if turning clockwise. As well as, rolls over from start value to max value if turning counter-clockwise. Turning clockwise provides positive measurements, counter-clockwise negative.

Byte 0		Byte 1		Byte 2	Byte 3	Byte 4	Byte 5	Byte 6	Byte 7
Bit 0 - 1	Button 4*	Bit 0 - 1	Encoder Button*	Reserved	Reserved	DiffCount LSB	DiffCount MSB	AbsCount LSB	AbsCount MSB
Bit 2 - 3	Button 3*	Bit 2 - 3	Button 7*						
Bit 4 - 5	Button 2*	Bit 4 - 5	Button 6*						
Bit 6 - 7	Button 1*	Bit 6 - 7	Button 5*						

\* States for buttons:

- 0 - Off
- 1 - On
- 2 - Error
- 3 - Not applicable

### HMR configuration Message Structure

The system shall receive the AUXIO2 message from J1939-71 that contains the LED control data for all 7 buttons and rotary encoder, message only allows for 3 colors choices and 1 blink rate of medium. This is the generic configuration.

<b>Allowed colors</b>	Index 0	Index 1	Index 2
<b>Allowed states</b>	0 - Off	1 - On	2 - Blink medium
<b>Value of 3</b>	Indicates no change		

	Byte 0 (Button 1)	Byte 1 (Button 2)	Byte 2 (Button 3)	Byte 3 (Button 4)	Byte 4 (Button 5)	Byte 5 Button 6	Byte 6 (Button 7)	Byte 7 (Encoder Button)
<b>Bit 6-7</b>	Backlight Color Index	Backlight Color Index	Backlight Color Index	Backlight Color Index	Backlight Color Index	Backlight Color Index	Backlight Color Index	Backlight 1 Color Index
<b>Bit 4-5</b>	Indicator Color Index	Indicator Color Index	Indicator Color Index	Indicator Color Index	Indicator Color Index	Indicator Color Index	Indicator Color Index	
<b>Bit 2-3</b>	LED 1 State	LED 1 State	LED 1 State	LED 1 State	LED 1 State	LED 1 State	LED 1 State	Backlight 1 State
<b>Bit 0-1</b>	LED 2 State	LED 2 State	LED 2 State	LED 2 State	LED 2 State	LED 2 State	LED 2 State	



## CAN messaging protocol

### LEDs

The system supports a proprietary message to set the RGB Color configuration for one of the color settings for the Indicator LED and overwrites any of the corresponding indexes of the RGB settings from the previous Backlight color table.

Byte 0	Byte 1	Byte 2	Byte 3	Byte 4	Byte 5	Byte 6	Byte 7
CMD_LED1_2 _COLOR LSB	CMD_LED1_2 _COLOR MSB	Color Index: 0-15	Red	Green	Blue		
		Reserved: 16-127	RGB 0-255	RGB 0-255	RGB 0-255		
		No change: 255					
		Bit 7					

### Blink rate and indicator configuration for buttons

The system supports an individual message that allows for setting all the blink rates and selection of colors for backlight and indicator for each button.

Type	Speed	Inverted
0 - Off	0 - Slow	0 - No
1 - On	1 - Medium	1 - Yes
2 - Blink	2 - Fast	2 Reserved
3 - Breathe	3-6 Reserved	3 - No Change
4-6 Reserved	7 - No Change	
7 - No Change		

Byte 0	Byte 1	Byte 2	Byte 3	Byte 4	Byte 5	Byte 6	Byte 7
CMD_BUTTON _LEDS LSB	CMD_BUTTON _LEDS MSB	Button #: 1-7	Backlight Color: 0-15	Backlight State:	Indicator Color: 0-15	LED1 State:	LED2 State:
		Reserved: 0; 8-254	Reserved: 16-254	Bit 0-2: Type	Reserved: 16-256	Bit 0-2: Type	Bit 0-2: Type
		No Change: 255	No Change: 255	Bit 3-5: Speed	No Change: 255	Bit 3-5: Speed	Bit 3-5: Speed
				Bit 6-7: Invert		Bit 6-7: Invert	Bit 6-7: Invert

### Blink rate and indicator configuration for rotary

The system supports an individual message that allows for setting all the blink rates and selection of colors for backlight for the encoder dial.

Type	Speed	Inverted
0 - Off	0 - Slow,	0 - No,
1 - On,	1 - Medium,	1 - Yes,
2 - Blink,	2 - Fast,	2 - Reserved,
3 - Breathe,	3-6 - Reserved,	3 - No Change
4-6 - Reserved,	7 - No Change	
7 - No Change		



### CAN messaging protocol

Byte 0	Byte 1	Byte 2	Byte 3	Byte 4	Byte 5	Byte 6	Byte 7
CMD_ENCODER _LEDS LSB	CMD_ENCODER _LEDS MSB	Encoder: 8	Backlight Color: 0-15	Backlight State:	Unused	Unused	Clear Counts:
		Reserved: 0-7; 9-254	Reserved: 16-254	Bit 0-2: Type	255	255	Clear - 1
		No Change: 255	No Change: 255	Bit 3-5: Speed Bit 6-7: Invert			No Change: 2-255

### Rotary encoder configuration

The encoder count value configuration must be done using PLUS+1® Service Tool, it allows for more customization to the rotary encoder.

Configuration	Value	Comments
Start Value	0 - Max Value	The delta value defines how many counts can be done with the rotary.
Maximum Range	Start Value - 65535	
Rollover	Enable/Disable	When max value is achieved the rotary is either:  <b>(Enabled)</b> Count begins at max or start value depending which way rotary is being turned. <b>(Disabled)</b> Reaches max or start value and does not go further.

**Installation and start-up**

**Dimensions**

*HMR CAN Rotary Input Device*

mm [in]

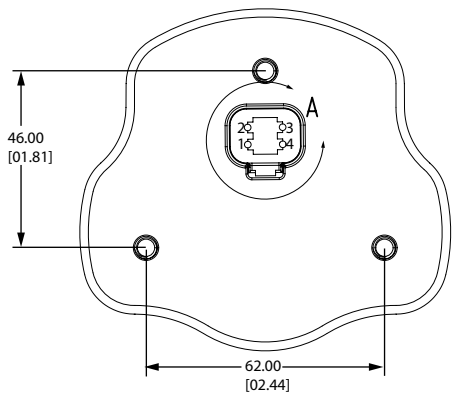
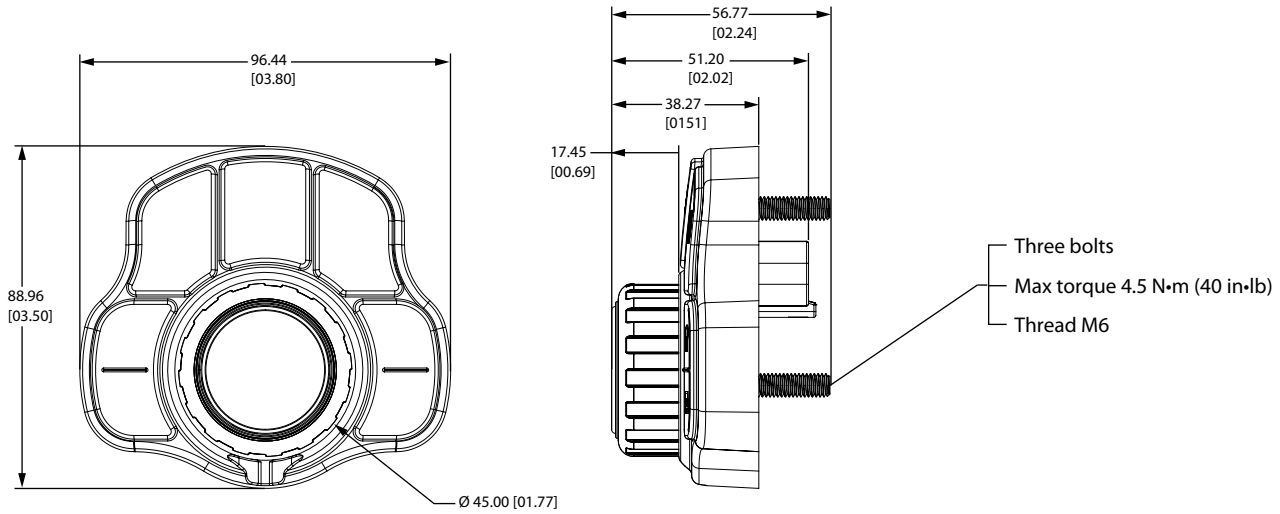

**Mounting**

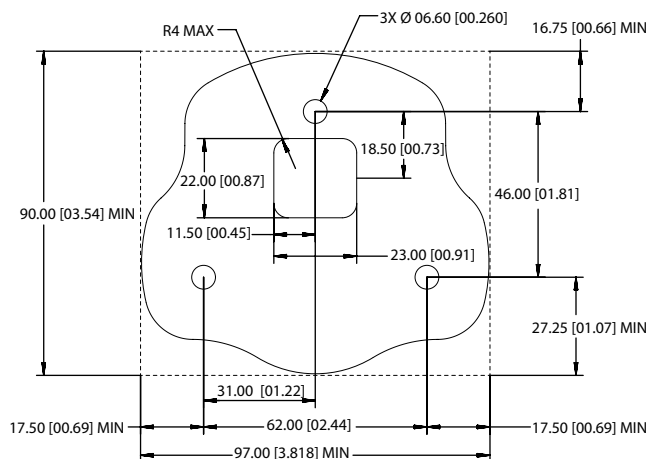

## Installation and start-up

### Connectors

#### Pin assignments

DEUTSCH DTM-4 pin connector

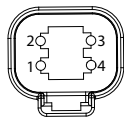

Pin	Controller function
1	Power ground -
2	Power supply +
3	CAN Hi
4	CAN Lo

### Machine wiring guidelines

#### Warning

Unintended movement of the machine or mechanism may cause injury to the technician or bystanders. Improperly protected power input lines against over current conditions may cause damage to the hardware. Properly protect all power input lines against over-current conditions. To protect against unintended movement, secure the machine.

#### Caution

Unused pins on mating connectors may cause intermittent product performance or premature failure. Plug all pins on mating connectors.

- Protect wires from mechanical abuse, run wires in flexible metal or plastic conduits.
- Use 85° C (185° F) wire with abrasion resistant insulation and 105° C (221° F) wire should be considered near hot surfaces.
- Use a wire size that is appropriate for the module connector.
- Separate high current wires such as solenoids, lights, alternators or fuel pumps from sensor and other noise-sensitive input wires.
- Run wires along the inside of, or close to, metal machine surfaces where possible, this simulates a shield which will minimize the effects of EMI/RFI radiation.
- Do not run wires near sharp metal corners, consider running wires through a grommet when rounding a corner.
- Do not run wires near hot machine members.
- Provide strain relief for all wires.
- Avoid running wires near moving or vibrating components.
- Avoid long, unsupported wire spans.
- Ground electronic modules to a dedicated conductor of sufficient size that is connected to the battery (-).
- Power the sensors and valve drive circuits by their dedicated wired power sources and ground returns.
- Twist sensor lines about one turn every 10 cm (4 in).
- Use wire harness anchors that will allow wires to float with respect to the machine rather than rigid anchors.

## Installation and start-up

### Machine welding guidelines

 **Warning**

---

High voltage from power and signal cables may cause fire or electrical shock, and cause an explosion if flammable gasses or chemicals are present.

Disconnect all power and signal cables connected to the electronic component before performing any electrical welding on a machine.

---

The following is recommended when welding on a machine equipped with electronic components:

- Turn the engine off.
- Remove electronic components from the machine before any arc welding.
- Disconnect the negative battery cable from the battery.
- Do not use electrical components to ground the welder.
- Clamp the ground cable for the welder to the component that will be welded as close as possible to the weld.







**Products we offer:**

- Bent Axis Motors
- Closed Circuit Axial Piston Pumps and Motors
- Displays
- Electrohydraulic Power Steering
- Electrohydraulics
- Hydraulic Power Steering
- Integrated Systems
- Joysticks and Control Handles
- Microcontrollers and Software
- Open Circuit Axial Piston Pumps
- Orbital Motors
- PLUS+1® GUIDE
- Proportional Valves
- Sensors
- Steering
- Transit Mixer Drives

**Danfoss Power Solutions** is a global manufacturer and supplier of high-quality hydraulic and electronic components. We specialize in providing state-of-the-art technology and solutions that excel in the harsh operating conditions of the mobile off-highway market. Building on our extensive applications expertise, we work closely with our customers to ensure exceptional performance for a broad range of off-highway vehicles.

We help OEMs around the world speed up system development, reduce costs and bring vehicles to market faster.

Danfoss – Your Strongest Partner in Mobile Hydraulics.

**Go to [www.powersolutions.danfoss.com](http://www.powersolutions.danfoss.com) for further product information.**

Wherever off-highway vehicles are at work, so is Danfoss. We offer expert worldwide support for our customers, ensuring the best possible solutions for outstanding performance. And with an extensive network of Global Service Partners, we also provide comprehensive global service for all of our components.

Please contact the Danfoss Power Solution representative nearest you.

**Comatrol**

[www.comatrol.com](http://www.comatrol.com)

**Turolla**

[www.turollaocg.com](http://www.turollaocg.com)

**Hydro-Gear**

[www.hydro-gear.com](http://www.hydro-gear.com)

**Daikin-Sauer-Danfoss**

[www.daikin-sauer-danfoss.com](http://www.daikin-sauer-danfoss.com)

Local address:

**Danfoss  
Power Solutions (US) Company**  
2800 East 13th Street  
Ames, IA 50010, USA  
Phone: +1 515 239 6000

**Danfoss  
Power Solutions GmbH & Co. OHG**  
Krokamp 35  
D-24539 Neumünster, Germany  
Phone: +49 4321 871 0

**Danfoss  
Power Solutions ApS**  
Nordborgvej 81  
DK-6430 Nordborg, Denmark  
Phone: +45 7488 2222

**Danfoss  
Power Solutions Trading  
(Shanghai) Co., Ltd.**  
Building #22, No. 1000 Jin Hai Rd  
Jin Qiao, Pudong New District  
Shanghai, China 201206  
Phone: +86 21 3418 5200

Danfoss can accept no responsibility for possible errors in catalogues, brochures and other printed material. Danfoss reserves the right to alter its products without notice. This also applies to products already on order provided that such alterations can be made without changes being necessary in specifications already agreed. All trademarks in this material are property of the respective companies. Danfoss and the Danfoss logotype are trademarks of Danfoss A/S. All rights reserved.