

# SINGLE-STAGE VACUUM GENERATORS 15 01 10 and 15 03 10

Single-stage vacuum generator operation is based on the Venturi principle.

Supplying the generator with compressed air in P, vacuum will be generated at connection U, while both the supply and the sucked air will be released through R.

By interrupting the air supply in P, the vacuum effect in U will also stop.

Vacuum generators 15 01 10 and 15 03 10 are generally used for controlling vacuum cups, for gripping and handling non-porous objects and equipment with low capacity requirements.

They are fully made with anodised aluminium.

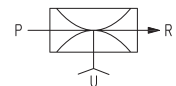
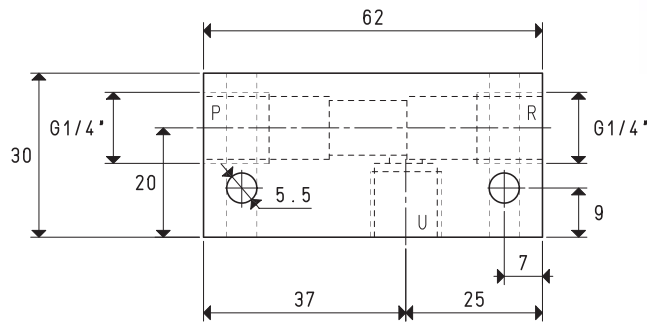
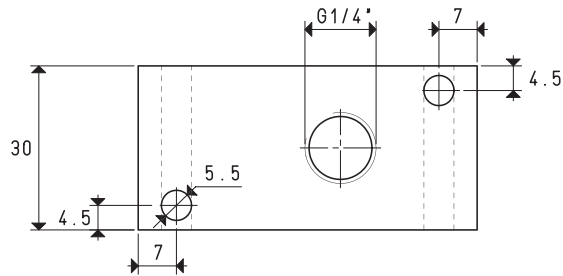

P=COMPRESSED AIR CONNECTION

R=EXHAUST

U=VACUUM CONNECTION

Art.	15 01 10		
Quantity of sucked air	cum/h	2.7	2.8
Max. vacuum level	-kPa	55	70
Final pressure	mbar abs.	450	300
Supply pressure	bar (g)	4	5
Air consumption	l/s	0.7	0.8
Working temperature	°C		-20 / +80
Noise level	dB(A)		63
Weight	g		140

**Note:** All the vacuum data indicated in the table are valid at the normal atmospheric pressure of 1013 mbar and are obtained with a constant supply pressure.

## SINGLE-STAGE VACUUM GENERATORS WITH EJECTOR 15 02 10 and 15 04 10

The operation of these single-stage vacuum generators is based on the Venturi principle. Supplying the generator with compressed air in P, vacuum will be generated at connection U, while both the supply and the sucked air will be released through R. At the same time, the chamber contained in the generator is also supplied and, as soon as the supply in P is interrupted, it discharges the compressed air that had been collected in it through connection U, thus rapidly restoring the atmospheric pressure at the service.

If, for example, a vacuum cup is connected to the service U, thanks to this system it will disconnect much rapidly than with the vacuum generators described previously. They are fully made with anodised aluminium.

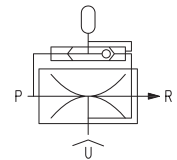
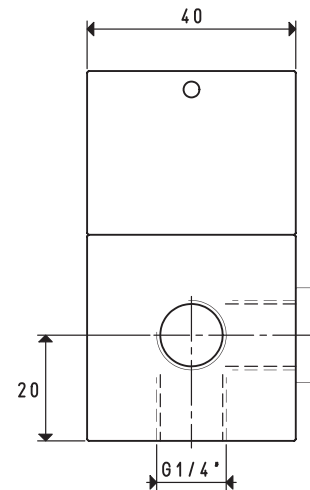
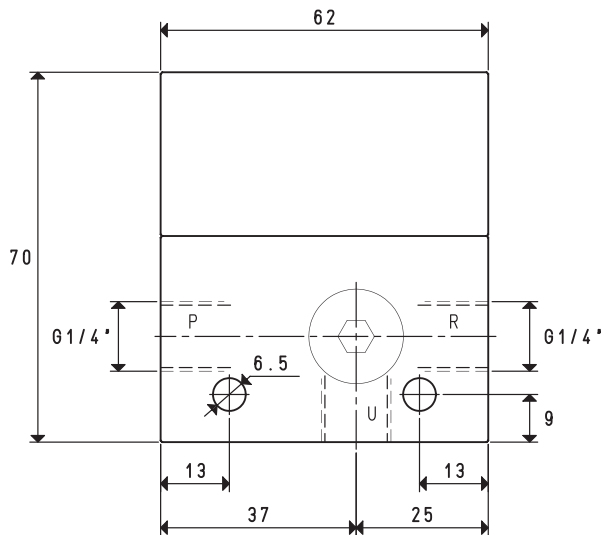

P=COMPRESSED AIR CONNECTION

R=EXHAUST

U=VACUUM CONNECTION

Art.	15 02 10			
Quantity of sucked air	cum/h	2.7	2.8	2.8
Max. vacuum level	-kPa	55	70	83
Final pressure	mbar abs.	450	300	170
Supply pressure	bar (g)	4	5	6
Air consumption	NI/s	0.7	0.8	0.9
Working temperature	°C			-20 / +80
Noise level	dB(A)			63
Weight	g			319
Spare parts				
Sealing kit	art.			00 15 500

**Note:** All the vacuum data indicated in the table are valid at the normal atmospheric pressure of 1013 mbar and are obtained with a constant supply pressure.

## IN-LINE SINGLE-STAGE VACUUM GENERATORS PVP 1

This new range of vacuum generators also exploits the Venturi principle. Their distinctive feature compared with traditional vacuum generators are the two air and vacuum supply connections located in-line, while the exhaust connection of the sucked and exhaust air is orthogonal to them and it is located on the on the generator circumference.

These vacuum generators are easy to disassemble, thus allowing visibility and access to all the components. The advantages of these generators include reduced overall dimensions, easy maintenance and easy assembly to the vacuum cup supports or to the vacuum cup holders. As a standard, they are equipped with pressed stainless steel suction filtre and a special microfibre silencer, which is wrapped around the exhaust connection, making them particularly silent. They are fully made with anodised aluminium.

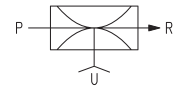
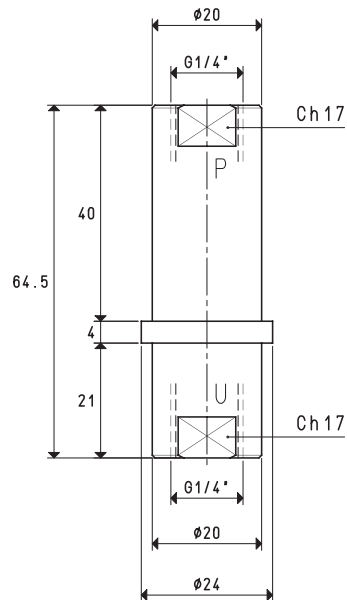

P=COMPRESSED AIR CONNECTION

R=EXHAUST

U=VACUUM CONNECTION

Art.	PVP 1			
Quantity of sucked air	cum/h	0.9	1.0	1.0
Max. vacuum level	-KPa	60	80	85
Final pressure	mbar abs.	400	200	150
Supply pressure	bar (g)	3	4	5
Air consumption	NI/s	0.5	0.6	0.8
Working temperature	°C	-20 / +80		
Noise level	dB(A)	62		
Weight	g	44		
<b>Spare parts</b>				
Silencer	art.			00 15 114
Suction filtre	art.			SP 1/4 I

**Note:** All the vacuum data indicated in the table are valid at the normal atmospheric pressure of 1013 mbar and are obtained with a constant supply pressure.

# IN-LINE SINGLE-STAGE VACUUM GENERATORS GV 1, GV 2 and GV 3

The operation of these vacuum generators is also based on the Venturi principle.

Their distinctive feature compared with traditional vacuum generators are the two air and vacuum supply connections located in-line, while the exhaust connection of the sucked and exhaust air is orthogonal to them.

The advantages of these generators include reduced overall dimensions, easy maintenance and easy assembly. These vacuum generators can be assembled directly onto the vacuum cup supports or vacuum cup holders. They are fully made with anodised aluminium, except for the exhaust nozzle which is made with brass.

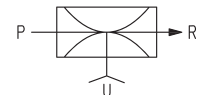
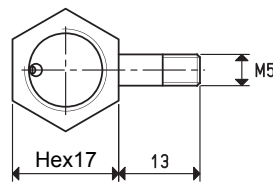
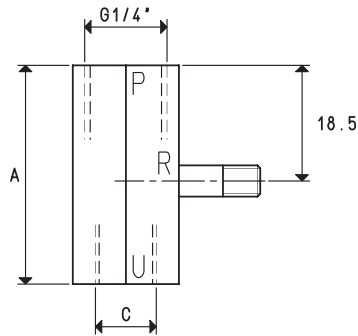

P=COMPRESSED AIR CONNECTION		R=EXHAUST		U=VACUUM CONNECTION					
Art.				GV1		GV2		GV3	
Quantity of sucked air	cum/h	1.0	1.0	1.0	1.0	1.0	1.0	1.0	1.0
Max. vacuum level	-kPa	60	75	85	60	75	85	60	75
Final pressure	mbar abs.	400	250	150	400	250	150	400	250
Supply pressure	bar (g)	3	4	5	3	4	5	3	4
Air consumption	NI/s	0.5	0.6	0.7	0.5	0.6	0.7	0.5	0.6
Working temperature	°C			-20 / +80		-20 / +80		-20 / +80	
Noise level	dB(A)			70		70		70	
Weight	g			19		20		21	
A				30		35		38	
C	∅			M5		G1/8"		G1/4"	

**Note:** All the vacuum data indicated in the table are valid at the normal atmospheric pressure of 1013 mbar and are obtained with a constant supply pressure.

3D drawings available at [www.vuototecnica.net](http://www.vuototecnica.net)

## SINGLE-STAGE VACUUM GENERATORS PVP 2 M

The vacuum generators described in this page are also based on the Venturi principle and share the same technical features as the previous ones. Their distinctive feature is their shape.

The vacuum connection U, in fact, is threaded to allow the assembly of a vacuum cup with a male 3/8" threaded gas support, while in-line, but on the opposite side an M 10 threaded hole allows installing the generator directly onto the machine or on the cup holders with springing device. They are fully made with anodised aluminium, with brass ejectors.

Equipped with a vacuum cup, they are true independent gripping units.

These vacuum generators are suited for vacuum cup operated loaders or handlers, for gripping sheet steel, glass slabs, plastic panels and other similar products.

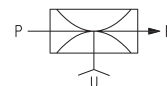
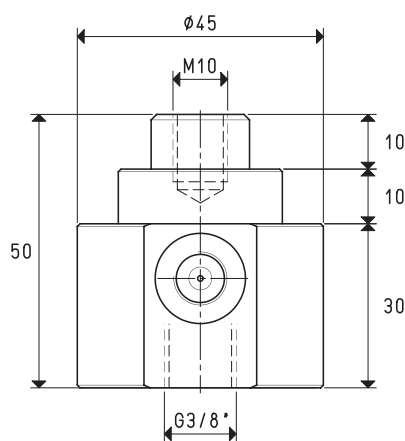
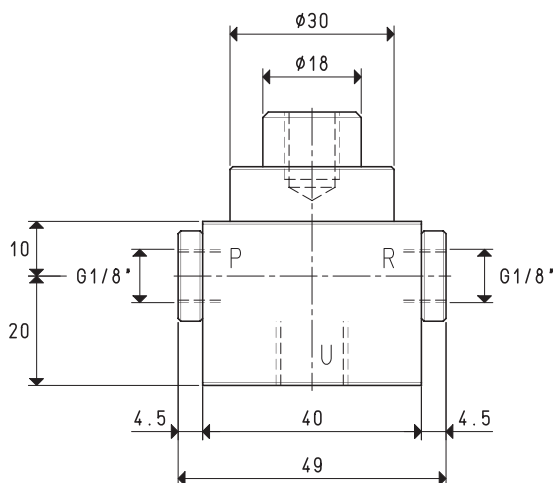

P=COMPRESSED AIR CONNECTION

R=EXHAUST

U=VACUUM CONNECTION

Art.	PVP 2 M			
Quantity of sucked air	cum/h	2.8	2.9	3.0
Max. vacuum level	-KPa	60	70	85
Final pressure	mbar abs.	400	300	150
Supply pressure	bar (g)	4	5	6
Air consumption	NI/s	0.7	0.9	1.0
Working temperature	°C			-20 / +80
Noise level	dB(A)			78
Weight	g			162

**Note:** All the vacuum data indicated in the table are valid at the normal atmospheric pressure of 1013 mbar and are obtained with a constant supply pressure.

# SINGLE-STAGE VACUUM GENERATORS PVP 7 X

Vacuum generators PVP 7 X also exploit the Venturi principle. Their distinctive feature compared to PVP 2 and PVP 3 is their greater suction capacity, thanks to the association of two ejectors in parallel.

A special silencer made with sintered ceramic is installed on their exhaust, making them particularly silent.

As a standard, they are equipped with a vacuum gauge for a direct reading of the vacuum level.

An additional connection on the body of the generator allows the installation of a mini vacuum switch for signalling the vacuum level, or of a pneumatic solenoid valve for a quick restoration of the atmospheric pressure at the service.

They are fully made with anodised aluminium, with stainless steel ejectors.

These vacuum generators can be used for connecting one or more vacuum cups or equipment with capacity requirements within the shown values.

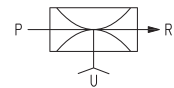
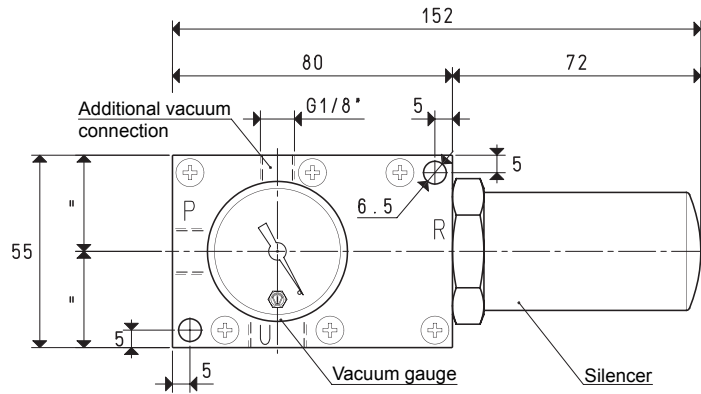
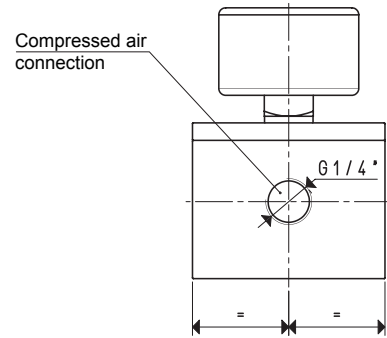
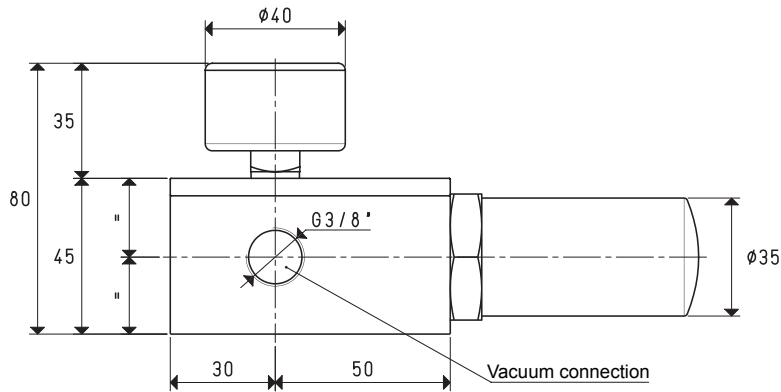

P=COMPRESSED AIR CONNECTION      R=EXHAUST      U=VACUUM CONNECTION

Art.	PVP 7 X			
Quantity of sucked air	cum/h	8.5	8.8	8.9
Max. vacuum level	-kPa	60	73	85
Final pressure	mbar abs.	400	270	150
Supply pressure	bar (g)	4	5	6
Air consumption	NI/s	2.3	2.8	3.2
Working temperature	°C	-20 / +80		
Noise level	dB(A)	63		
Weight	g	470		
Spare parts				
Sealing kit	art.	00 15 276		
Vacuum gauge	art.	09 03 15		
Silencer	art.	00 15 55		

**Note:** All the vacuum data indicated in the table are valid at the normal atmospheric pressure of 1013 mbar and are obtained with a constant supply pressure.

3D drawings available at [www.vuototecnica.net](http://www.vuototecnica.net)

# SINGLE-STAGE VACUUM GENERATORS PVP 7 SX

Vacuum generators PVP 7X share the same mechanical and technical features as the previously described ones. Their distinctive feature is a state of the art silencer installed on them and made with natural fibre sound absorbing material contained in a special cylindrical anodised aluminium enclosure open on the exhaust.

This prevents the silencer from being clogged and allows the vacuum generator to suck oil or water condensation saturated fluids mixed with fine and impalpable dust.

They can be used as PVP 7X and, in addition, they can also operate in humid or dusty environments.

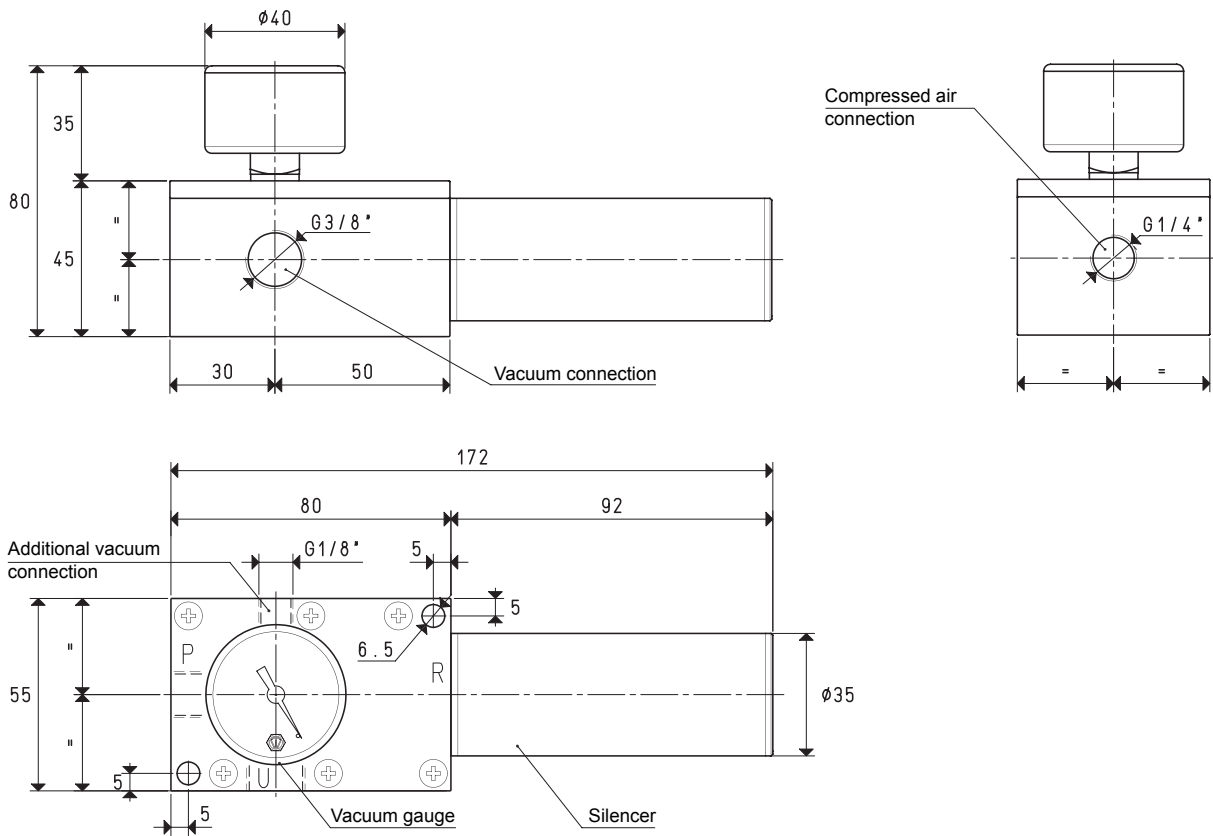

3D drawings available at [www.vuototecnica.net](http://www.vuototecnica.net)

		P=COMPRESSED AIR CONNECTION	R=EXHAUST	U=VACUUM CONNECTION	
<b>Art.</b>					<b>PVP 7 SX</b>
<b>Quantity of sucked air</b>	cum/h	8.5	8.8	8.9	
<b>Max. vacuum level</b>	-kPa	60	73	85	
<b>Final pressure</b>	mbar abs.	400	270	150	
<b>Supply pressure</b>	bar (g)	4	5	6	
<b>Air consumption</b>	l/s	2.3	2.8	3.2	
<b>Working temperature</b>	°C				-20 / +80
<b>Noise level</b>	dB(A)				63
<b>Weight</b>	g				470
<b>Spare parts</b>					
<b>Sealing kit</b>	art.				00 15 276
<b>Vacuum gauge</b>	art.				09 03 15
<b>Silencer</b>	art.				SSX 3/4 R

**Note:** All the vacuum data indicated in the table are valid at the normal atmospheric pressure of 1013 mbar and are obtained with a constant supply pressure.



# MULTI-STAGE VACUUM GENERATORS SERIES M

These vacuum generators feature multiple state of the art ejectors assembled onto small modules. One of their distinctive features is their great suction capacity compared to their reduced size.

With a compressed air supply of 4 ÷ 5 bar (g), they can produce a maximum vacuum equal to 85% and a suction capacity of 3.6 ÷ 18 cum/h, according to the number of modules.

The silencer is built-in.

They are fully made with slightly anodised alloys and can be installed in any position. The multi-stage vacuum generators in this range are suited for interconnecting vacuum cup gripping systems and, in particular, in the industrial robotics sector, which requires equipment with excellent working performance, but with weight and size reduced to the minimum.

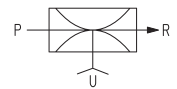
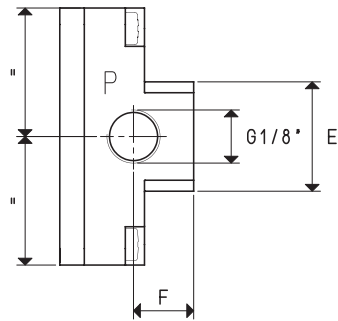
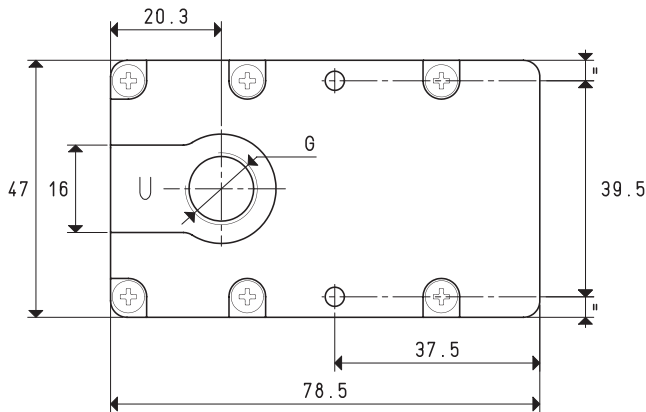
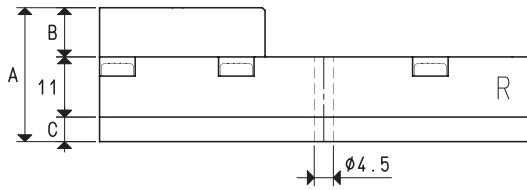

P=COMPRESSED AIR CONNECTION      R=EXHAUST      U=VACUUM CONNECTION

Art.				M 3			M 7
Quantity of sucked air	cum/h	3	3.4	3.6	5.4	5.8	6.2
Max. vacuum level	-KPa	62	82	85	62	82	85
Final pressure	mbar abs.	380	180	150	380	180	150
Supply pressure	bar (g)	3	4	5	3	4	5
Air consumption	NI/s	0.5	0.7	0.8	0.8	1.2	1.4
Working temperature	°C			-10 / +80			-10 / +80
Noise level	dB(A)			64			70
Weight	g			109			111
A				24.5			25.5
B				9			10
C				4.5			4.5
E	∅			20			24
F				11			12
G	∅			G1/4"			G3/8"
Spare parts							
Sealing kit and reed valve	art.			00 KIT M 3			00 KIT M 7

**Note:** All the vacuum data indicated in the table are valid at the normal atmospheric pressure of 1013 mbar and are obtained with a constant supply pressure.

Conversion ratio: inch =  $\frac{mm}{25.4}$ ; pounds =  $\frac{g}{453.6}$  =  $\frac{Kg}{0.4536}$

GAS-NPT thread adapters available at page 1.117



# MULTI-STAGE VACUUM GENERATORS SERIES M.. SSX

These vacuum generators share the same technical features as the others of the M series described above. Their distinctive feature is their silent operation.

In fact, along with the built-in silencer, they also have an external SSX silencer for a further noise reduction.

These generators are particularly recommended in work environments where the noise level must be kept within very low values.

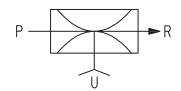
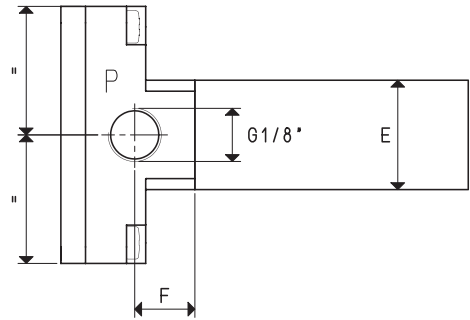
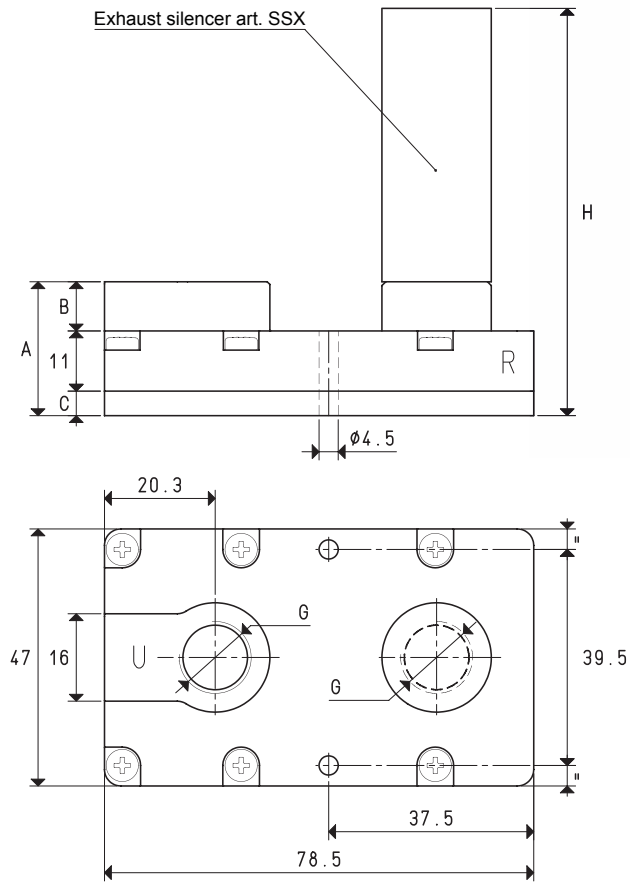

P=COMPRESSED AIR CONNECTION      R=EXHAUST      U=VACUUM CONNECTION

Art.				M 3 SSX			M 7 SSX
Quantity of sucked air	cum/h	3.0	3.4	3.6	5.4	5.8	6.2
Max. vacuum level	-KPa	62	82	85	62	82	85
Final pressure	mbar abs.	380	180	150	380	180	150
Supply pressure	bar (g)	3	4	5	3	4	5
Air consumption	NI/s	0.5	0.7	0.8	0.8	1.2	1.4
Working temperature	°C			-10 / +80			-10 / +80
Noise level	dB(A)			52			58
Weight	g			109			111
A				24.5			25.5
B				9			10
C				4.5			4.5
E	∅			20			29
F				11			12
G	∅			G1/4"			G3/8"
H				74.5			97.5
Spare parts							
Silencer	art.			SSX 1/4"			SSX 3/8"
Sealing kit and reed valve	art.			00 KIT M 3			00 KIT M 7

**Note:** All the vacuum data indicated in the table are valid at the normal atmospheric pressure of 1013 mbar and are obtained with a constant supply pressure.

Conversion ratio: inch =  $\frac{mm}{25.4}$ ; pounds =  $\frac{g}{453.6}$  =  $\frac{Kg}{0.4536}$

GAS-NPT thread adapters available at page 1.117

## MULTI-STAGE AND MULTI-FUNCTION VACUUM GENERATORS SERIES MVG

*These generators are true independent vacuum units that can control an entire vacuum gripping system. Their distinctive features are their compact size and great suction capacity.*

*They are composed of a monobloc anodised aluminium structure onto which are assembled:*

- *A modular and silenced multi-stage vacuum generator.*
- *A micro solenoid valve for supplying compressed air to the generator.*
- *A micro solenoid valve for blowing the exhaust compressed air.*
- *An adjustable flow regulator for dosing the exhaust air.*
- *A unidirectional check valve, located on the suction inlet, for maintaining the vacuum in case of electricity failure.*
- *A digital vacuum switch provided with display and commutation LEDs, for managing the compressed air supply and for signalling the safety cycle start-up.*
- *An anodised aluminium manifold provided with vacuum connections and a built-in filter easy to inspect.*

*By activating the compressed air solenoid valve, the generator creates vacuum at the service. Once the preset maximum value is reached, the vacuum switch acts on the solenoid valve electric coil and interrupts the air supply, restoring it when the vacuum value returns below the minimum value.*

*Along with maintaining the vacuum level within preset safety values (hysteresis), this modulation allows saving a considerable amount of compressed air.*

*A second vacuum switch signal, also adjustable and independent from the first, can be used to start up the cycle when the vacuum level is suitable for the application. Once the working cycle is completed, the compressed air supply is deactivated and, at the same time, the ejection micro solenoid valve is activated for a quick restoration of the atmospheric pressure at the application.*

*MVG multi-function vacuum generators can be installed in any position and are suited for interconnecting vacuum gripping systems for handling sheet steel, glass, marble, ceramic, plastic, cardboard, wood, etc., and, in particular, for the industrial robotics sector which requires equipment with excellent performance and with size and weight reduced to the minimum.*



## MODULAR MULTI-STAGE AND MULTI-FUNCTION VACUUM GENERATORS SERIES GVMM

*Modular multi-function vacuum generators are true independent vacuum units that offer an entire vacuum control system.*

*They feature a reduced thickness and weight compared to their suction capacity and they have been designed to be assembled with screws to one or more intermediate modules MI. The original internal connection system for the compressed air supply allows communication with no need for external manifolds.*

*This modular system allows increasing the number of independent vacuum units according to the requirements. In fact, you can order a multi-function vacuum generator and the intermediate modules with the desired capacities, already assembled, or you can assemble one or more intermediate modules to the GVMM generator that has already been installed on the machine, without having to make particular modifications. GVMM vacuum generators are composed of an anodised aluminium monobloc with lid, inside of which the silenced multiple ejectors are installed and the vacuum chamber and the compressed air supply connection are contained.*

*The following items are assembled externally:*

- A micro solenoid valve for supplying compressed air to the generator.
- A micro solenoid valve for blowing the exhaust compressed air.
- An adjustable flow regulator for dosing the exhaust air.
- A digital vacuum switch with display and commutation LEDs for managing the compressed air supply and for signalling the safety cycle start-up.
- An anodised aluminium or transparent plexiglas manifold provided with vacuum connections with built-in suction filter, easy to inspect, and a check valve for maintaining the vacuum in case of electricity or compressed air failure.

*By activating the compressed air solenoid valve, the generator creates vacuum at the service. Once the preset maximum value is reached, the vacuum switch acts on the solenoid valve electric coil and interrupts the air supply, restoring it when the vacuum value returns below the minimum value.*

*Along with maintaining the vacuum level within preset safety values (hysteresis), this modulation allows saving a considerable amount of compressed air.*

*A second vacuum switch signal, also adjustable and independent from the first, can be used to start up the cycle when the vacuum level is suitable for the application. Once the working cycle is completed, the compressed air supply is deactivated and, at the same time, the ejection micro solenoid valve is activated for a quick restoration of the atmospheric pressure at the application.*

*GVMM multi-function vacuum generators can be installed in any position and are suited for interconnecting vacuum gripping systems for handling sheet steel, glass, marble, ceramic, plastic, cardboard, wood, etc., and, in particular, for the industrial robotics sector which requires equipment with excellent performance and several independent vacuum units for controlling several applications but with reduced size and weight.*

